

YASNAC LX3

CNC SYSTEM FOR TURNING APPLICATIONS

CONNECTING MANUAL

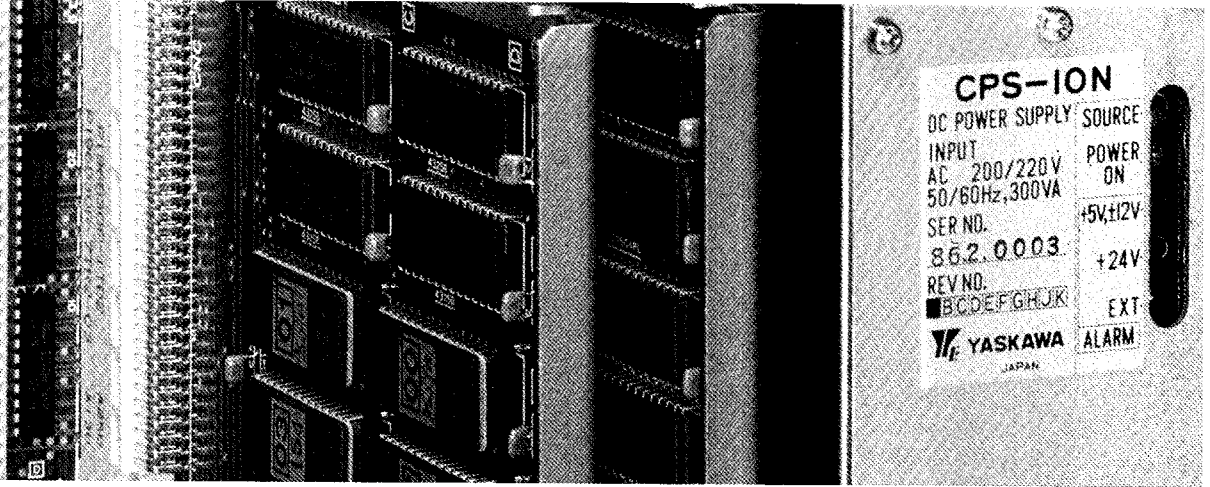

Before initial operation read these instructions thoroughly, and retain for future reference.



YASKAWA

YASNAC LX3 is an ultraspeed dual processor CNC for turning lathes and a combination of two high-performance 16-bit microprocessors running in parallel. This manual describes the specifications for connecting YASNAC LX3 with machines, machine interfaces and external equipment.

Necessary connections to be provided by the machine manufacturer differ depending on the type of the CNC cabinet supplied by Yaskawa. Make additions or deletions of connections in accordance with the combination for standard cabinets and integrated units.

The programmable controller system (hereafter called PC) is installed in the YASNAC LX3 CNC cabinet. For details of the PC, refer to Instruction Manual for YASNAC LX3/MX3 PC System (TOE-C843-9.1).

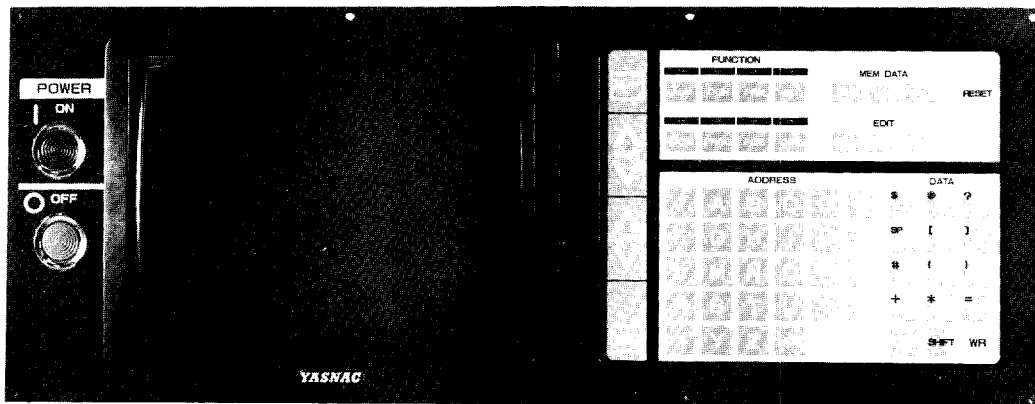

586-175

YASNAC LX3 Operator's Station

CONTENTS

	Page
1. CONFIGURATION	1
1.1 SYSTEM CONFIGURATION.....	1
1.2 STANDARD CABINETS AND INTEGRATED UNITS.....	1
2. ENVIRONMENTAL CONDITIONS	1
3. CABINET CONSTRUCTION DESIGN	1
4. CABINET DESIGN FOR HEAT FACTORS	3
4.1 SELECTION OF HEAT EXCHANGER	3
4.2 HEAT VALUES OF UNITS	3
5. CABLE ENTRANCE	4
5.1 LAYOUT OF CABLE CONNECTORS	4
5.2 CLAMPING CABLES, AND GROUNDING CABLE SHIELD	4
6. CONNECTION DIAGRAMS	5
7. POWER SUPPLY CONNECTION	6
7.1 POWER SUPPLY CONNECTION TO CPU MODULE	6
7.2 POWER SUPPLY CONNECTION TO STANDARD CABINETS	6
8. CONNECTING POWER UNIT (TYPE CPS-10N) AND PC BOARD (TYPE JANCD-PC20) TO CRT OPERATOR'S PANEL (CRT/P)	7
9. CONNECTION OF MANUAL PULSE GENERATOR (HPG)	8
10. CONNECTION OF INPUT SEQUENCE	8
10.1 CONNECTION	8
10.2 DETAILS OF SIGNALS	9
11. CONNECTION TO FEED SERVO UNITS (SVX AND SVZ)	10
12. CONNECTION TO SPINDLE DRIVE UNIT (SDU)	12
13. CONNECTION TO SPINDLE PULSE GENERATOR (SPG)	13
14. CONNECTION TO RS-232C INTERFACE	13
14.1 CONNECTION.....	13
14.2 RS-232C INTERFACE	14
15. DIRECT-IN SIGNAL CONNECTION	16
16. CONNECTION TO GENERAL-PURPOSE I/O SIGNALS	17
16.1 I/O PORTS.....	17
16.2 I/O CIRCUITS OF I/O PORTS	17
16.3 I/O SIGNAL INTERFACE	19
17. CABLES	39
17.1 LIST OF CABLES	39
17.2 LIST OF CONNECTORS.....	40
17.3 SPECIFICATIONS OF CABLE.....	40
18. STANDARD I/O SIGNALS	42
18.1 LIST OF NC STANDARD I/O SIGNALS	42
18.2 DETAILS OF SIGNALS	48
APPENDIX A DIMENSIONS in mm	73
APPENDIX B I/O PORT ADDRESS SETTING	81
APPENDIX C STANDARD WIRING COLORS OF YASNAC	82

INDEX

Subject	Chapter	Section	Page
A Alarm and Input Error Outputs	18	18. 2. 26	56
Auxiliary Function Lock Input	18	18. 2. 18	55
C CABINET CONSTRUCTION DESIGN	3		1
CABINET DESIGN FOR HEAT FACTORS	4		3
CABLE ENTRANCE	5		4
CABLES	17		39
CLAMPING CABLES, AND GROUNDING CABLE SHIELD	5	5. 2	4
Combined Fixed Cycle Cutting Override Inputs	18	18. 2. 48	71
CONFIGURATION	1		1
CONNECTING POWER UNIT AND PC BOARD TO CRT OPERATOR'S PANEL	8		7
CONNECTION	10	10. 1	8
CONNECTION	14	14. 1	13
CONNECTION DIAGRAMS	6		5
CONNECTION OF INPUT SEQUENCE	10		8
CONNECTION OF MANUAL PULSE GENERATOR	9		8
CONNECTION TO FEED SERVO UNITS	11		10
CONNECTION TO GENERAL-PURPOSE I/O SIGNALS	16		17
CONNECTION TO RS-232C INTERFACE	14		13
CONNECTION TO SPINDLE DRIVE UNIT	12		12
CONNECTION TO SPINDLE PULSE GENERATOR	13		13
CPU Module	17	17. 2. 1	40
CRT Operator's Panel	17	17. 2. 2	40
Current Value Storing Input	18	18. 2. 15	54
D DETAILS OF SIGNALS	10	10. 2	9
DETAILS OF SIGNALS	18	18. 2	48
DIMENSIONS in mm		APPENDIX A	73
DIRECT-IN SIGNAL CONNECTION	15		16
Display Reset Inputs	18	18. 2. 33	59
Dry Run Input	18	18. 2. 14	54
E Edit Lock	18	18. 2. 17	55
Emergency Stop Input	10	10. 2. 2	9
Emergency Stop On Output	18	18. 2. 23	56
End-of-program Input, Rewind Input	18	18. 2. 32	58
ENVIRONMENTAL CONDITIONS	2		1
External Data Input Inputs/Outputs	18	18. 2. 45	68
External Power On-Off Input	10	10. 2. 3	9
External Reset Input and Reset On Output	18	18. 2. 24	56
External Store, Match, and Output Inputs	18	18. 2. 34	59
External Work Number Search A Inputs	18	18. 2. 40	62
F Feed Drive Unit	17	17. 2. 3	40
Feed Override/Manual Jogging Speed Selection Input	18	18. 2. 7	51
H HEAT VALUES OF UNITS	4	4. 2	3
High-speed Rewind and Start Input	18	18. 2. 50	72
I Input and Output for Control Operation Modes	18	18. 2. 2	48
Input Signals for Cycle Start, Stop Output Signals	18	18. 2. 1	48
Interlock Input	18	18. 2. 25	56
Interruption Point Return Input	18	18. 2. 20	55
IO 20 Boards	16	16. 3. 1	19
I/O Board Type JANCD-IO 20	16	16. 2. 1	17
I/O Board Type JANCD-SP 20	16	16. 2. 2	18
I/O CIRCUITS OF I/O PORTS	16	16. 2	17
I/O PORT ADDRESS SETTING		APPENDIX B	81
I/O PORTS	16	16. 1	17
I/O SIGNAL INTERFACE	16	16. 3	19

INDEX (Cont'd)

Subject	Chapter	Section	Page
L LAYOUT OF CABLE CONNECTORS	5	5.1	4
LIST OF CABLES	17	17.1	39
LIST OF CONNECTORS	17	17.2	40
LIST OF NC STANDARD I/O SIGNALS	18	18.1	42
M M, S, and T Codes Inputs/Outputs	18	18.2.29	57
Machine Lock and Display Lock Input	18	18.2.13	54
Machine-ready Input	18	18.2.22	56
Macro Program Input/Output Function	18	18.2.44	68
Manual Absolute On/Off Input	18	18.2.10	52
Manual Feed Axis Direction Selection Input	18	18.2.5	50
Manual Handle Feed Axis Selection Input	18	18.2.4	50
Manual Handle/Step Multiplication Factor Input	18	18.2.6	50
Manual Rapid Traverse Selection Input	18	18.2.3	50
N NC Power On and Servo Power On	10	10.2.1	9
NC Unit	4	4.2.1	3
O Optional Block Skip Input	18	18.2.12	54
Overload Input	10	10.2.4	9
Overtravel Inputs	18	18.2.21	55
P Positioning Completion Outputs	18	18.2.30	58
POWER SUPPLY CONNECTION	7		6
POWER SUPPLY CONNECTION TO CPU MODULE	7	7.1	6
POWER SUPPLY CONNECTION TO STANDARD CABINETS	7	7.2	6
Program Restart Input	18	18.2.16	55
R Rapid Feedrate Override Input	18	18.2.8	51
Rapid Threading Pull-out Input	18	18.2.27	56
Reference Point Return Control I/O Signals	18	18.2.9	52
RS-232C INTERFACE	14	14.2	14
S S4-Digit Command External Outputs	18	18.2.39	62
S4-Digit Commands Inputs/Outputs	18	18.2.35	59
SELECTION OF HEAT EXCHANGER	4	4.1	3
Servo Power On Input	18	18.2.49	72
Servo Unit	4	4.2.2	3
Setup Point Return Input	18	18.2.19	55
Single Block Input	18	18.2.11	53
Skip Input	18	18.2.47	71
SPECIFICATIONS OF CABLE	17	17.3	40
Spindle Indexing Function Input/Output	18	18.2.42	63
Spindle S Command "0," Gear Shift On Input	18	18.2.36	61
Spindle Speed Override Inputs	18	18.2.38	61
Spindle Speed Reached Input	18	18.2.37	61
STANDARD CABINETS AND INTEGRATED UNITS	1	1.2	1
STANDARD I/O SIGNALS	18		42
STANDARD WIRING COLORS OF YASNAC	APPENDIX C		82
Stored Stroke Limit 3 by Tool Inputs/Outputs	18	18.2.43	67
SYSTEM CONFIGURATION	1	1.1	1
T Time Count Input	18	18.2.41	63
Tool Life Control Inputs/Outputs	18	18.2.46	70
Travel On and Thread Cutting On Outputs	18	18.2.31	58
X X-axis Mirror Image Input	18	18.2.28	57

1. CONFIGURATION

1.1 SYSTEM CONFIGURATION

The system configuration of YASNAC LX3 is shown below.

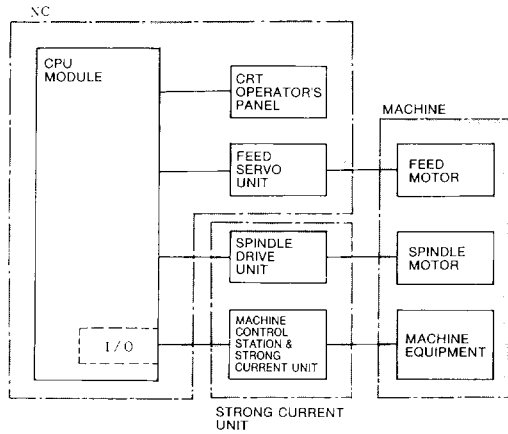

Fig. 1.1 System Configuration of YASNAC LX3

1.2 STANDARD CABINETS AND INTEGRATED UNITS

The available standard cabinets and the integrated units are shown in Table 1.1. Those units that cannot be installed in the cabinets must be installed in cabinets manufactured by machine manufacturers.

Table 1.1 Standard Cabinets and Integrated Units

Unit \ Cabinet	Standard Free-Standing Type	Custom Cabinet
CPU Module	○	○
CRT Operator's Panel	□	□
Tape Reader (optional)	□	□
Feed Servo Unit	○	□
Machine Control Station	□	□
Spindle Drive Unit	×	□
Strong Current Unit	×	□

○: Installed □: Can be installed ×: Cannot be installed

Note: Contact machine manufacturer for custom cabinets.

2. ENVIRONMENTAL CONDITIONS

- (1) Ambient Temperature
 - During operation: 0 to 45°C
 - During storage: -20°C to + 60°C
- (2) Relative Humidity:
 - 10 to 90% RH(non-condensing)
- (3) Vibration: 0.5 G or less

3. CABINET CONSTRUCTION DESIGN

Take the following into consideration when cabinets to contain the CPU rack and other units are designed.

- (1) Make sure that the cabinets are of a totally-enclosed type. The feed servo unit and spindle drive unit can be open type cabinets provided the following considerations are made:
 - (a) An air filter is provided at the external air inlet.
 - (b) Forced air used in the inside is not blown directly on the units. Direct blowing of air may cause oil mist or dust to settle on the units and might cause failures.
 - (c) The air discharge outlet should be positioned where dust and oil mist do not enter. The heat sink of the feed servo and spindle drive units can be installed outside for higher thermal efficiency. The cabinets should be of a totally-enclosed type to improve reliability.
- (2) Design the cabinet so that the difference between the inner-air temperature and ambient temperature is less than 10°C. Read par. 4 for cabinet design to accommodate heat.
- (3) Install a fan inside totally-enclosed cabinets to improve the internal cooling efficiency and to prevent localized temperature increases by circulating air inside the cabinets. The velocity of the circulating air should be greater than 2 ms on the surfaces of the printed circuit boards. Forced air should not blow directly on the printed circuit boards.
- (4) Provide spacing of more than 100 mm between components and cabinet walls for smooth flow of air.
- (5) Seal the cable openings, doors, etc. completely. The CRT unit operates at a particularly high voltage and collects dust in the air. Special caution is needed. The cabinet for mounting the CRT unit requires the following precautions:
 - (a) Use packing material on the mounting surface to eliminate gaps.
 - (b) Use packing material in the cable openings and doors.
- (6) Magnetic Deflection of CRT Display

CRT displays are sometimes deflected due to external magnetic influences. Sources that generate magnetic fields, such as transformers, reactors, fans, solenoid switches and relays, and AC power cables should be positioned more than 300 mm from the CRT unit. This distance is optimum and may vary for each circumstance. Determine the component layout beforehand.

3. CABINET CONSTRUCTION DESIGN (Cont'd)

- (7) To prevent malfunction due to noise, mount the units more than 100 mm from cables feeding 90 VDC or greater, AC power lines, and other components. The following precautions should be complied with during wiring:
 - (a) Separate AC and DC cables.
 - (b) Separate the primary and secondary sides of transformers, line filters, etc.
- (8) The front panels of the units that are exposed to the cabinet surfaces, such as the CRT unit, tape reader, and PO unit should be of a dust-proof type. However, do not install them in locations where cutting fluid may directly splash on them. Be sure to seal completely around the mounting sections.
- (9) Mount the units so as to allow easy checking, removal and reinstalling during maintenance work.
- (10) Read the instruction manuals of the feed servo and spindle drive units when mounting them. Heat sink should be installed outside the cabinet to reduce internal thermal losses. This increases the possibilities for a change from an open type to a totally-enclosed type and reduces the capacity of the heat exchanger.

Example

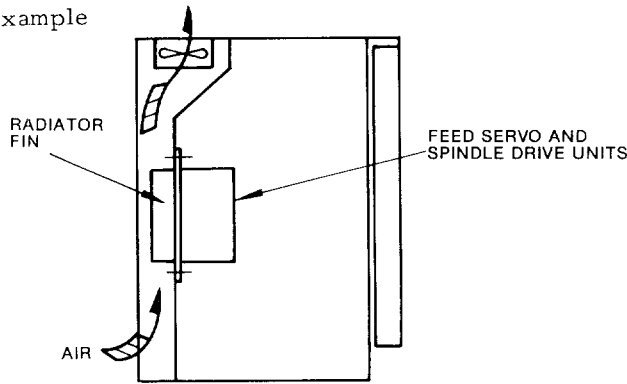

- (11) Precautions for Mounting CPU Rack
 - Observe the following points particularly during mounting of the CPU rack:
 - (a) Mount the unit in the direction shown in Fig. 3.1.

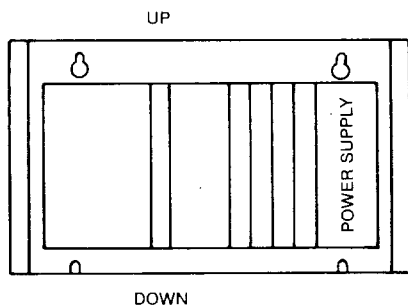
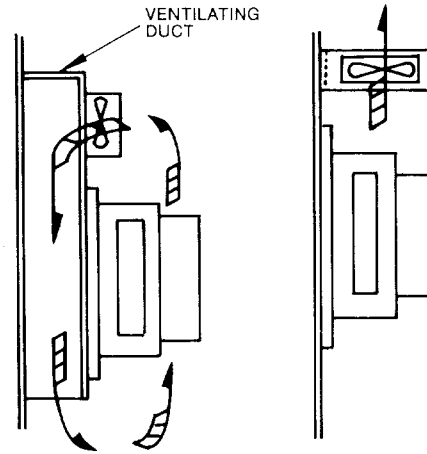
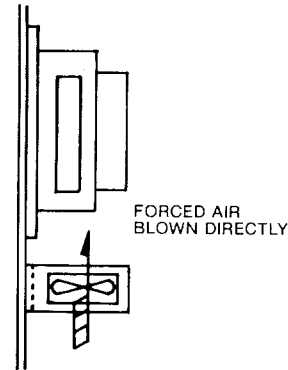

Fig. 3.1 Mounting of Units

- (b) Allow forced air at more than 2 ms to circulate inside the unit. Be careful not to blow air directly on the surfaces of the printed circuit boards.



(a) Good



(b) Poor

Fig. 3.2 Mounting of Fan

- (c) Provide spacing of more than 50 mm in the upper section and 100 mm in the lower section of the unit for better ventilation and easier maintenance.
- (d) Calculate the allowable heat value P_v' that ensures the temperature increase within cabinet (ΔT) to be less than 10°C .

$$P_v' = k \cdot A \cdot \Delta T \quad (\text{w})$$

$\Delta T \rightarrow 10^\circ\text{C}$
 $k \rightarrow 6 \text{ w} / (\text{m}^2 \cdot ^\circ\text{C})$

- (e) A heat exchanger is not needed if total heat value $P_v \leq$ allowable heat value P_v' .
- (f) A heat exchanger has to be installed with the following heat exchange ratio (heat exchanger capacity) q_h if total heat value $P_v >$ allowable heat value P_v' .

$$q_h = (P_v - P_v') / \Delta T \quad (\text{w} / ^\circ\text{C})$$

$\Delta T \rightarrow 10^\circ\text{C}$

4. CABINET DESIGN FOR HEAT FACTORS

4.1 SELECTION OF HEAT EXCHANGER

The cabinets to contain the CPU module and other units should be of a totally-enclosed type. The inner-air temperature differential inside the cabinets should be less than 10°C. Heat exchangers may be needed inside the cabinets depending on the heat generated by the installed electric equipment. Determine the heat exchanger capacity as follows:

ΔT : Air temperature rise inside cabinet(°C)

P_v : Total heat generated by electric equipment (w)

k : Cabinet heat transmission [$W/(m^2 \cdot ^\circ C)$]
Calculate based on $6W/(m^2 \cdot ^\circ C)$ if a circulating fan is installed.

A : Effective radiation area of cabinet(m^2)

qh : Heat exchange ratio of necessary heat exchanger.

1. Calculate the total heat value P_v of the electric equipment.

$$P_v = \Sigma (\text{Heat value of each unit})$$

2. Calculate the effective heat radiation area A .

$$A = 2 \times \{W(\text{width}) \times H(\text{height})\} + 2 \{W(\text{width}) \times D(\text{depth})\} + 2 \{D(\text{depth}) \times H(\text{height})\}$$

The surfaces that are not exposed to external air are ineffective areas.

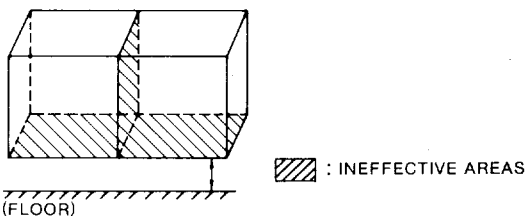

Note: If 50 mm or less from the floor, bottom areas are ineffective.

4.2 HEAT VALUES OF UNITS

4.2.1 NC UNIT

Table 4.1 Heat Values of NC Unit

Unit	Heat Value (W)
CPU Module	70
NC Operator's Panel	20
Tape Reader	25

4.2.2 SERVO UNIT

Table 4.2 Heat Value of Servo Unit

Unit Type CACR-	Total Heat Value (W)	Internal Heat Value (W)	Regenerative Resistance (W)
SR05SB	100	57	10-20
SR10SB	110	61	20-40
SR15SB	130	68	30-50
SR20SB	140	71	60-100
SR30SB	220	95	80-120
SR44BB	270	110	100-140

Note:

1. The servo unit uses two shafts, and its load factor should be 70 to 80%.
2. The internal heat value is the heat value remaining inside if the heat fin is installed outside.
3. Heat value created by regenerative resistance will differ depending on the frequency of rapid feed starts and stops.

5. CABLE ENTRANCE

5.1 LAYOUT OF CABLE CONNECTORS

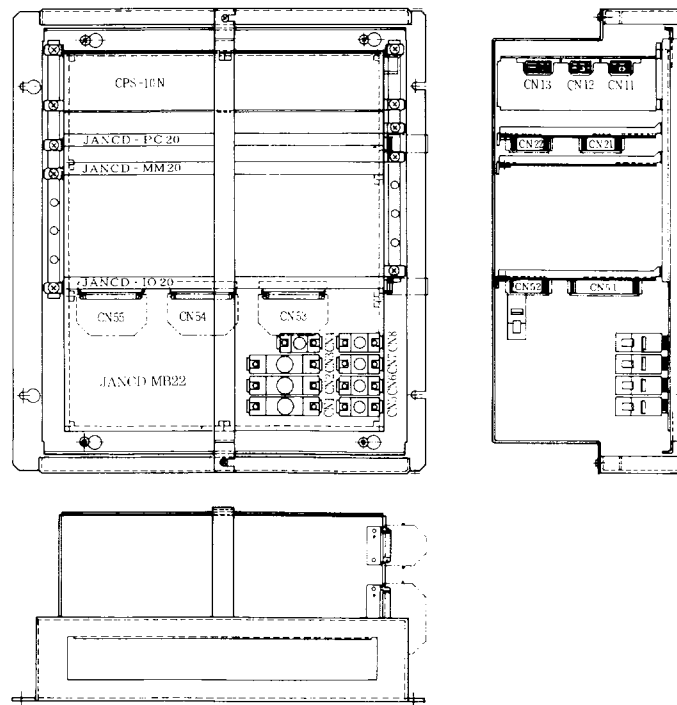
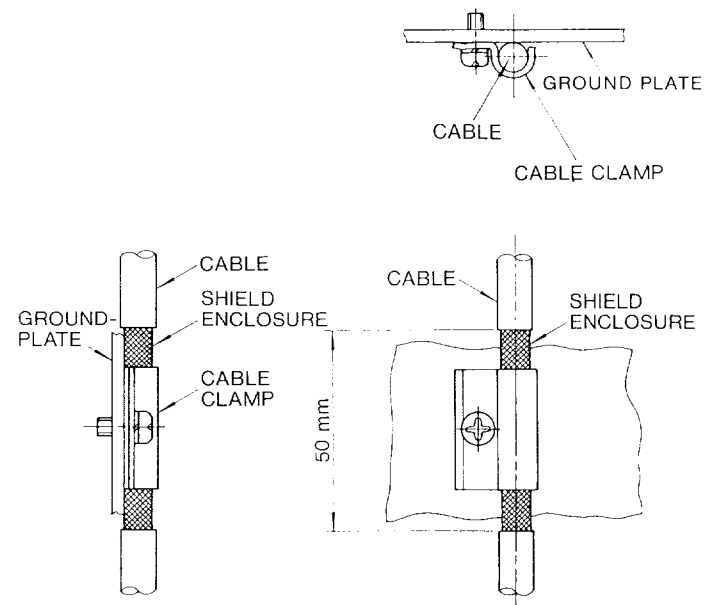

Fig. 5.1 Cable Entrance

5.2 CLAMPING CABLES, AND GROUNDING CABLE SHIELD

Be sure to clamp the cables connected to the YASNAC LX3 securely with the cable clamping fixtures found in the control panel.

For shielded cables, clamp the cables so that the shield is grounded securely to the plate after stripping the cable sheath as shown in Fig. 5.2.



Note: Non-shielded cables do not require stripping cable enclosure for clamping.

Fig. 5.2 Clamping of Shielded Cables

6. CONNECTION DIAGRAMS

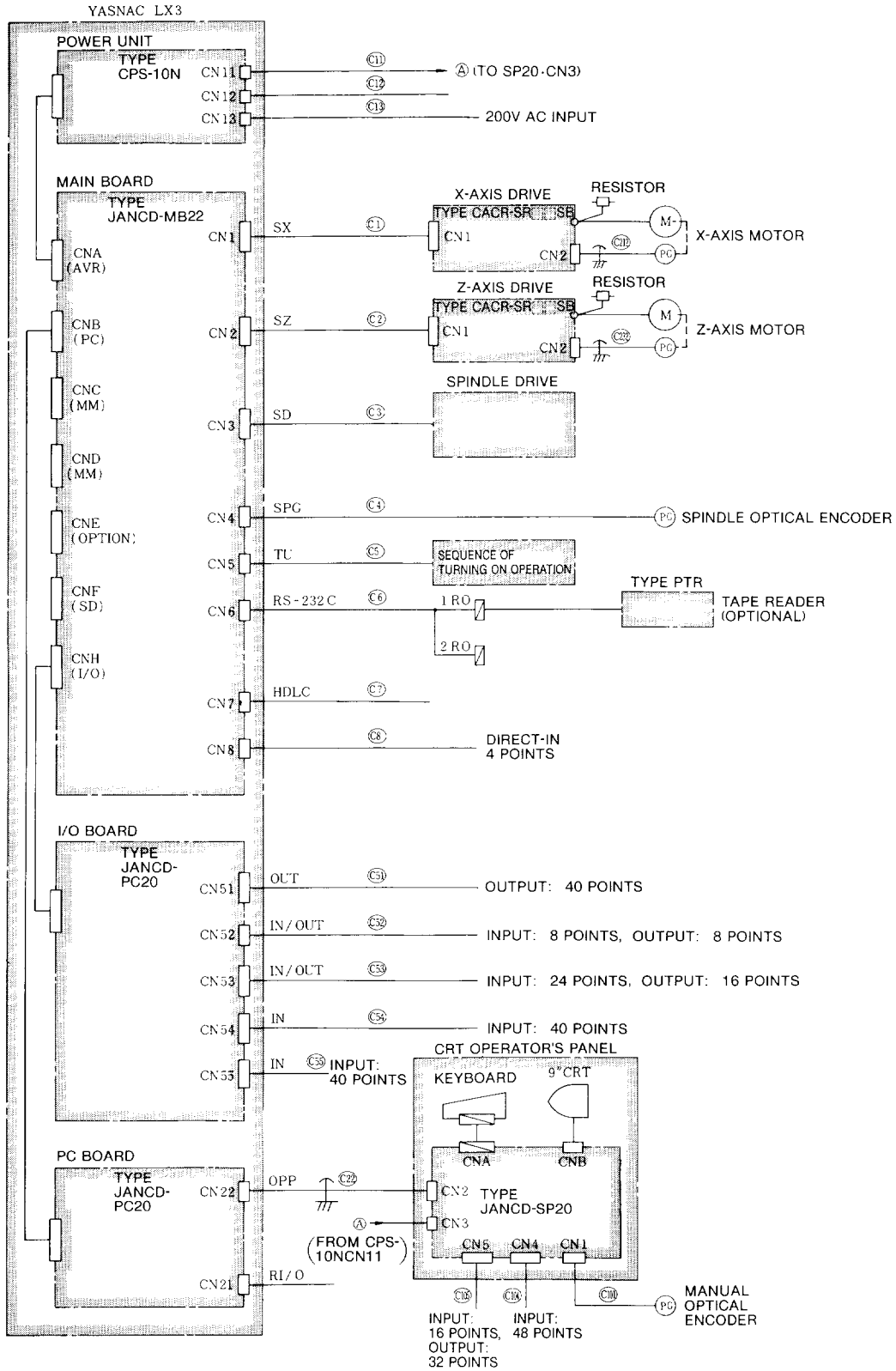

Note: Nos. in circle are cable Nos.
See Table 17.1 in detail.

Fig. 6.1

7. POWER SUPPLY CONNECTION

7.1 POWER SUPPLY CONNECTION TO CPU MODULE

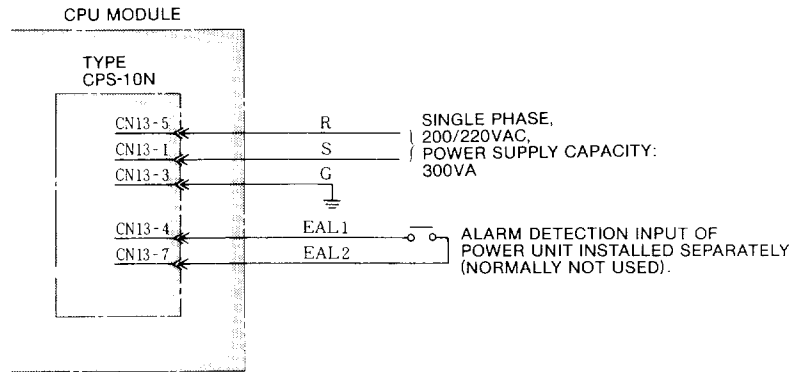
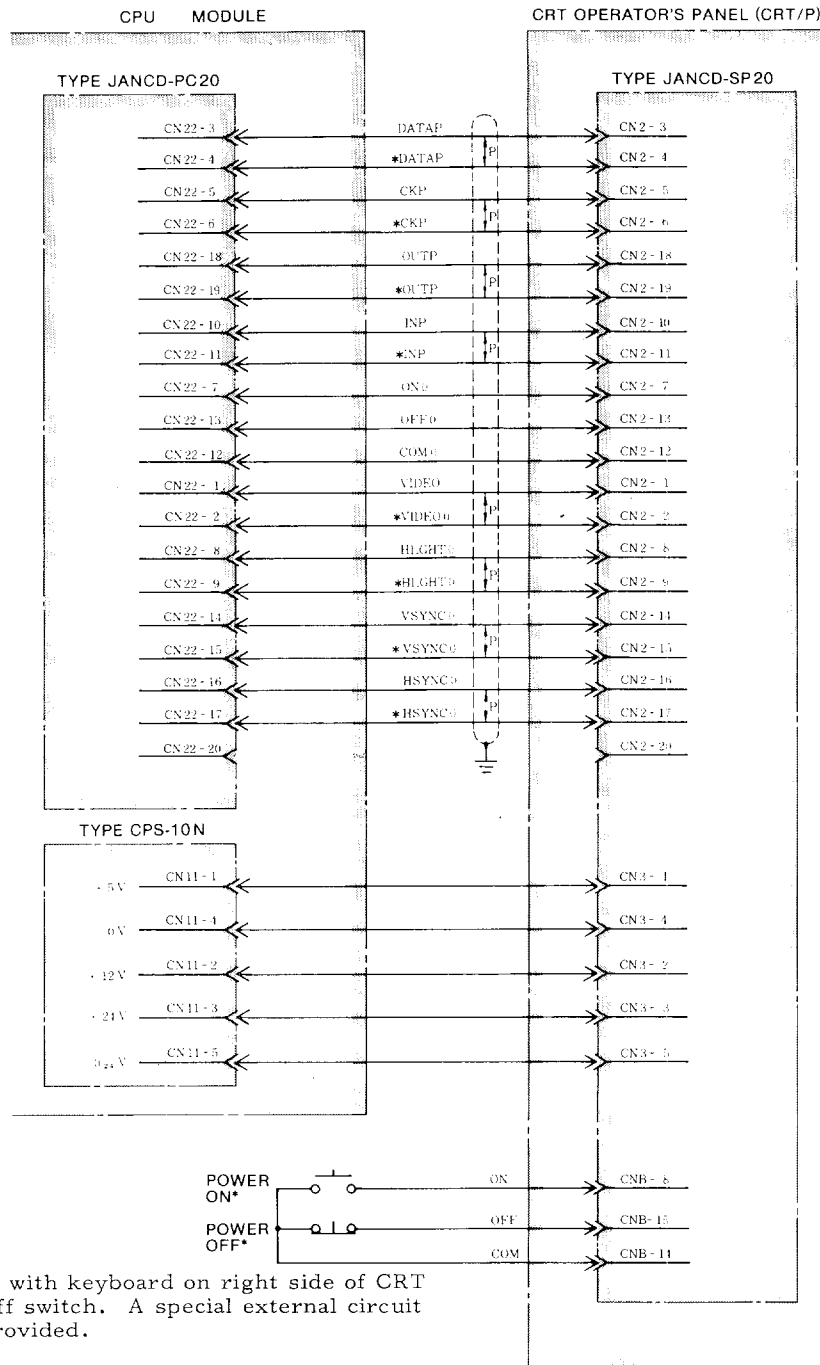

Fig. 7.1 Power Supply Connection to Power Unit Type CPS-10N

7.2 POWER SUPPLY CONNECTION TO STANDARD CABINETS

For details, contact your Yaskawa representative.

8. CONNECTING POWER UNIT (TYPE CPS-10N) AND PC BOARD (TYPE JANCD-PC20) TO CRT OPERATOR'S PANEL (CRT/P)



*NC operator's station with keyboard on right side of CRT contains a power on/off switch. A special external circuit does not have to be provided.

Note:

1. The shield enclosure does not have to be grounded outside.
2. Power on/off can be selected by the panel power on/off (POF) and/or remote power on/off (EOF) by a shorting plug.
3. Nos. 4 and 6 of SW5 must be set open.

Setting in Main board model JANCD-MB20

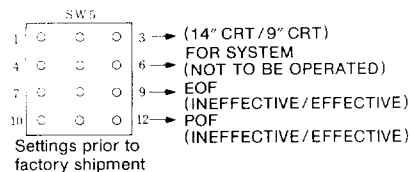
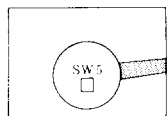

SW5 Setting

Power On/Off Input	Panel Power On/Off (POF)	Remote Power On/Off (EOF)	Panel and Remote Power On/Off																																																												
SW5	<table border="1"> <tr><td>1</td><td>○</td><td>○</td><td>○</td><td>3</td></tr> <tr><td>4</td><td>○</td><td>○</td><td>○</td><td>6</td></tr> <tr><td>7</td><td>○</td><td>○</td><td>○</td><td>9</td></tr> <tr><td>10</td><td>○</td><td>○</td><td>○</td><td>12</td></tr> </table>	1	○	○	○	3	4	○	○	○	6	7	○	○	○	9	10	○	○	○	12	<table border="1"> <tr><td>1</td><td>○</td><td>○</td><td>○</td><td>3</td></tr> <tr><td>4</td><td>○</td><td>○</td><td>○</td><td>6</td></tr> <tr><td>7</td><td>○</td><td>○</td><td>○</td><td>9</td></tr> <tr><td>10</td><td>○</td><td>○</td><td>○</td><td>12</td></tr> </table>	1	○	○	○	3	4	○	○	○	6	7	○	○	○	9	10	○	○	○	12	<table border="1"> <tr><td>1</td><td>○</td><td>○</td><td>○</td><td>3</td></tr> <tr><td>4</td><td>○</td><td>○</td><td>○</td><td>6</td></tr> <tr><td>7</td><td>○</td><td>○</td><td>○</td><td>9</td></tr> <tr><td>10</td><td>○</td><td>○</td><td>○</td><td>12</td></tr> </table>	1	○	○	○	3	4	○	○	○	6	7	○	○	○	9	10	○	○	○	12
1	○	○	○	3																																																											
4	○	○	○	6																																																											
7	○	○	○	9																																																											
10	○	○	○	12																																																											
1	○	○	○	3																																																											
4	○	○	○	6																																																											
7	○	○	○	9																																																											
10	○	○	○	12																																																											
1	○	○	○	3																																																											
4	○	○	○	6																																																											
7	○	○	○	9																																																											
10	○	○	○	12																																																											

Fig. 8.1

9. CONNECTION OF MANUAL PULSE GENERATOR (HPG)

(1) 1ST MANUAL PULSE GENERATOR

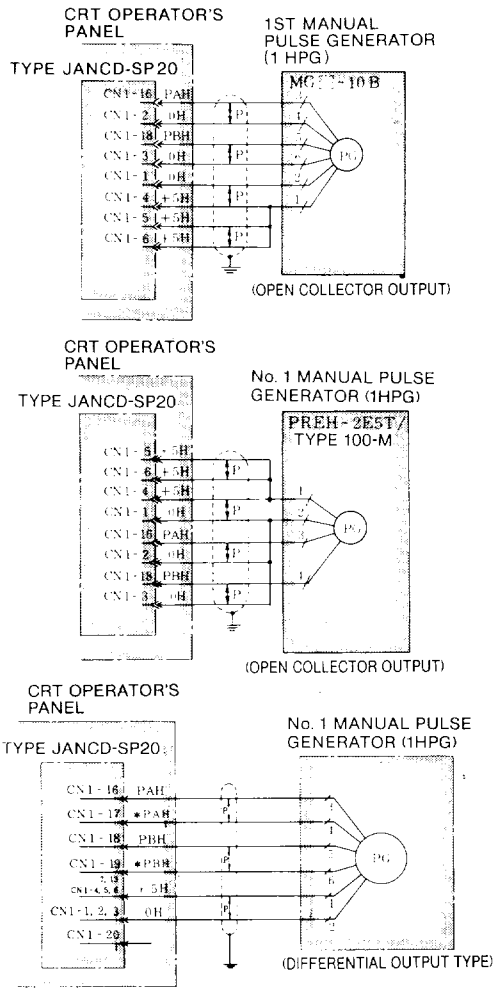

Note:

1. The HPG power supply is a constant +5 V.
2. Set SW1 on the SP20 board as follows depending on the manual pulse generator specifications.

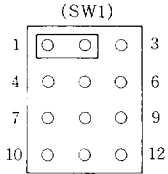

Simultaneous 1-axis control manual pulse generator
(Used for this interface.)

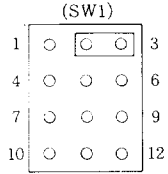

Simultaneous 2-axes control manual pulse generator
(For interfaces to be used, contact Yaskawa representative.)

3. An open collector (cable length 5 m or less) or differential output (cable length 5 m or more) can be used for HPG output.
4. Shielded cables are not needed if the cable lengths are less than 1 m. Twisted-pair cables can be used. Use twisted-pair shielded cables if the cable lengths are more than 1m and ground the cable shield enclosure using a ground plate.

Fig. 9. 1

10. CONNECTION OF INPUT SEQUENCE

10. 1 CONNECTION

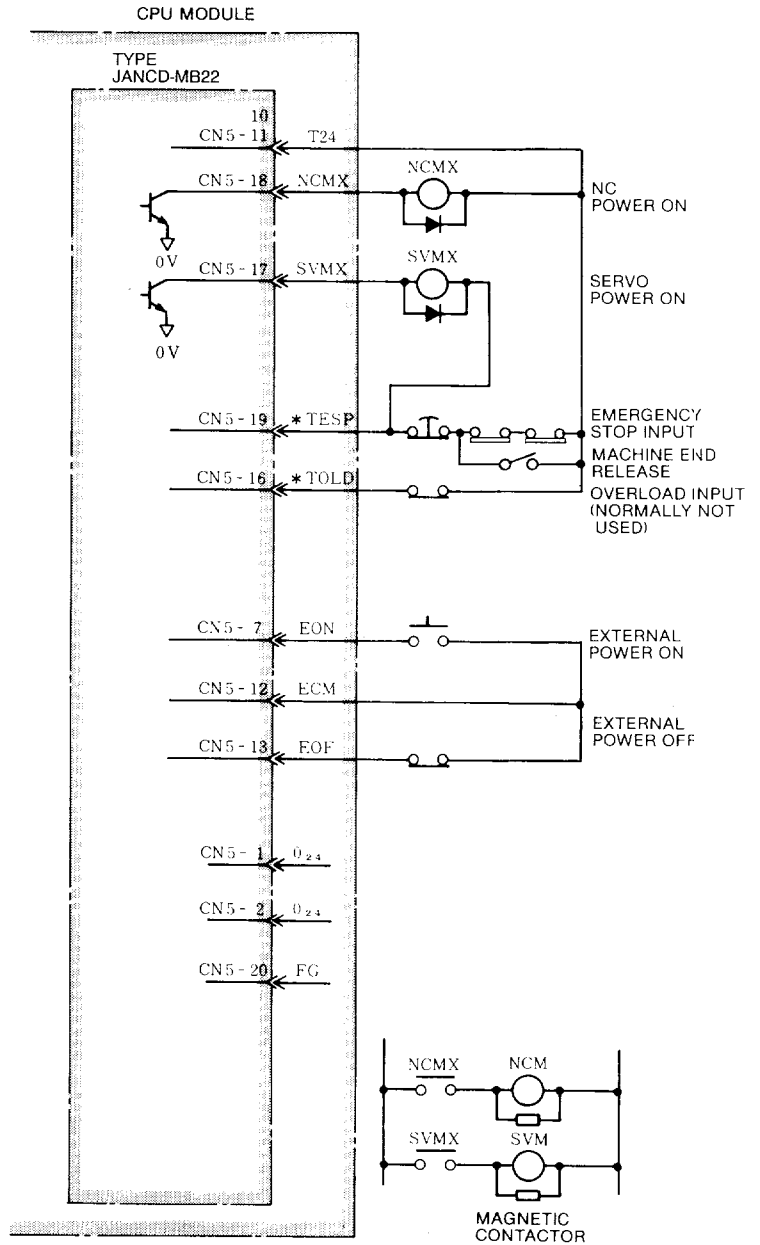

Fig. 10. 1 Connecting Input Sequence to Main Board (Type JANCD-MB22)

10.2 DETAILS OF SIGNALS

10.2.1 NC POWER ON (NCMX) AND SERVO POWER ON (SVMX)

- (1) NCMX: This output is turned on when the logic circuit of the control is energized.
- (2) SVMX: This output is turned on when the servo unit is energized. With an external servo unit, turn on the power supply when this signal is outputted.
- (3) The power supply turning on sequence is as follows:
 - (a) Close the power supply main switch for the control.
 - (b) Either push the POWER ON button on the NC operator's station, or close the circuit between EON and ECM. Then, the logic circuit and the servo control circuit are both energized, and the circuit between NCMX (NC power input and output) is closed.

With an external servo unit, design the servo control circuit power input sequence so that the circuit is energized at the output of NCMX signals.
 - (c) Again make the same power switching (pushing the POWER ON button or closing the circuit between EON and ECM). Now, the servo power supply is turned on, and the circuit between SVMX (servo power input and output) is closed.

With an external servo unit, design the servo power circuit power input sequence so that the circuit is energized at the output of SVMX signals.
 - (d) When the external circuit is ready after the circuit between SVMX is closed, and the control becomes ready, close the MRD (machine ready) input of the I/O module. Then, RDY is displayed on the CRT, and operation becomes possible.

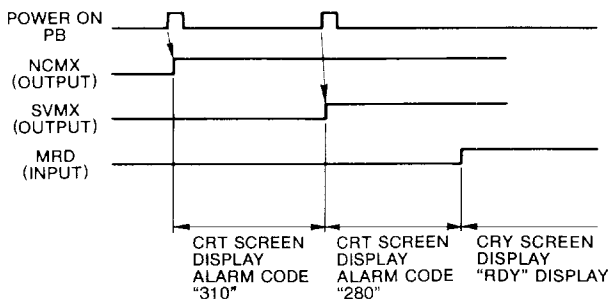

Fig. 10.2 Time Chart of Power Supply Turning on Sequence

10.2.2 EMERGENCY STOP(TESP) INPUT

When the circuit between emergency stop input terminals (TESP) is open, the control stops totally, the servo power supply is turned off, and the emergency stop output (*ESPS) of general purpose I/O module is opened.

10.2.3 EXTERNAL POWER ON-OFF (EON, EOF, ECM) INPUT

The control can be switched on and off by external input signals, in the same way as the depressing of the POWER ON/OFF buttons on the NC operator's station. When the circuit between EON and ECM is closed, the logic circuit or servo power of the control is energized. When the circuit between EOF and ECM is opened, the logic circuit or servo power of the control is deenergized.

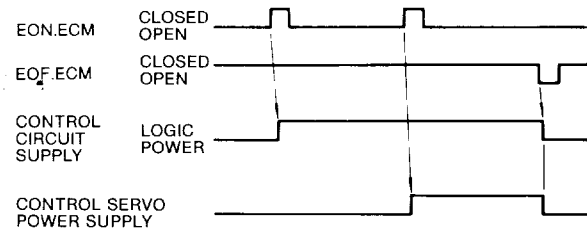

Fig. 10.3 External Power ON-OFF

10.2.4 OVERLOAD(*TOLD) INPUT

Short-circuit T24 (CN5-10) if this input is not used. (Normally this input is not used.)

11. CONNECTION TO FEED SERVO UNITS (SVX AND SVZ)

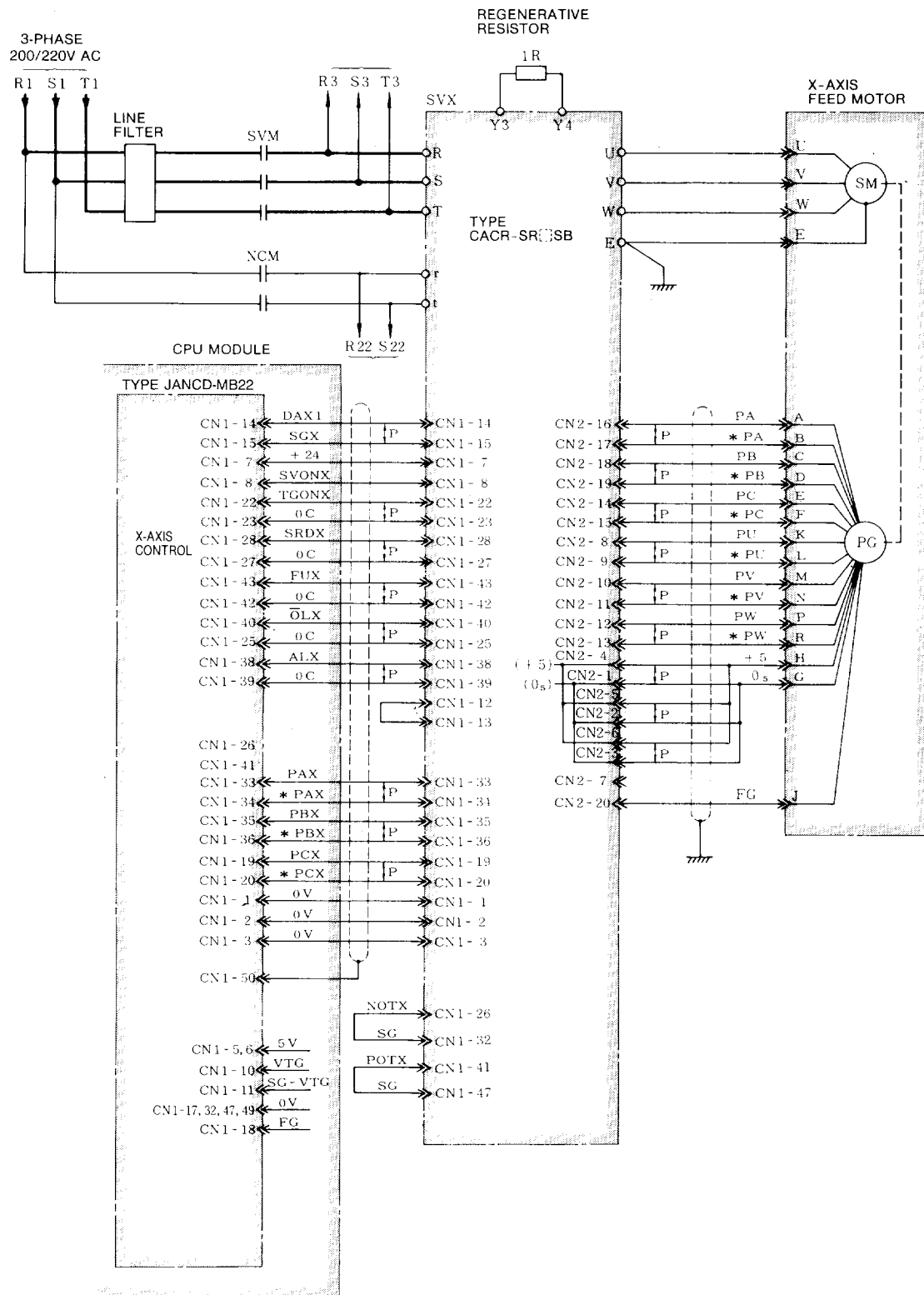

Fig. 11.1 Connection to Feed Servo Unit (SVX)

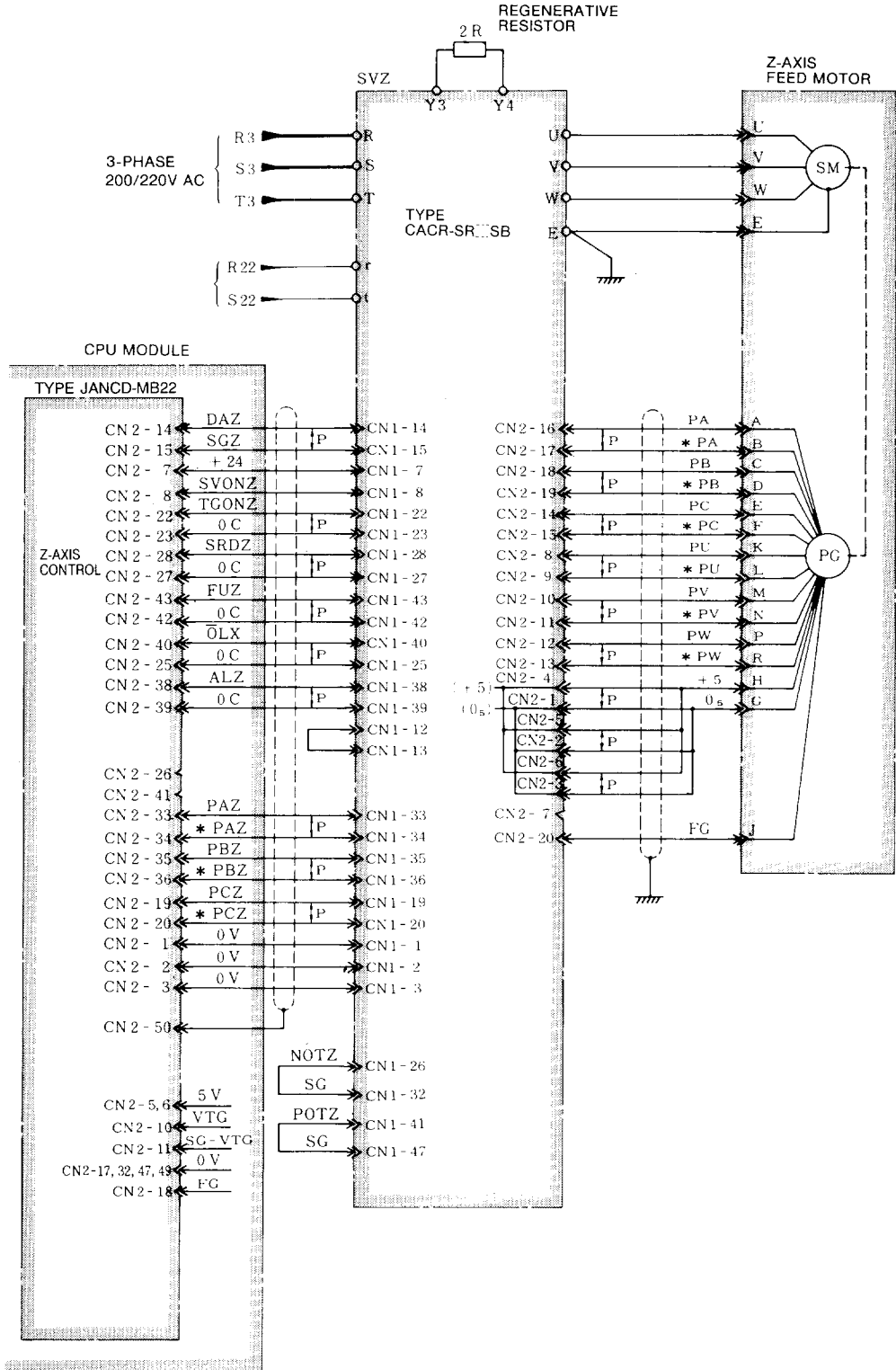
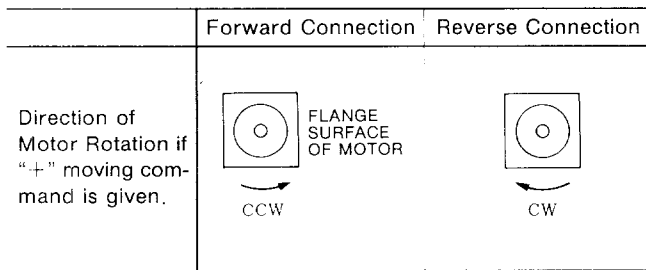

Fig. 11.2 Connection to Feed Servo Unit (SVZ)

11. CONNECTION TO FEED SERVO UNITS (SVX AND SVZ) (Cont'd)

(1) CONNECTION AND MOTOR ROTATING DIRECTION



The connection diagram shows forward connection. Connect wires as shown below for reverse connection.

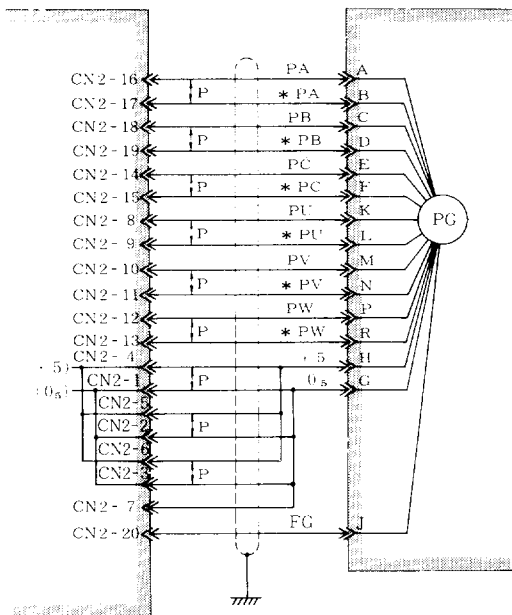

(2) COMBINATION OF DRIVE UNIT AND REGENERATIVE RESISTOR

Servo Drive Type CACR-	Regenerative Resistor installed Separately
SR05SB	4H-AS 30W 100-0HM
SR10SB	MRC12-500K
SR15SB	MRC12-500K
SR20SB	MRC22-250K
SR30SB	MRC22-250K
SR44SB	MRC22-250K

*Two resistors connected in parallel.

(3) LINE FILTER INSTALLATION

- A line filter is installed to prevent radio interference by high frequency generated by the servo drive unit.
- Select the appropriate filter as follows depending on the current per phase of the drive unit input power supply.

Line Filter Type	Current per Phase of Input Power Supply
LF310	10 A max
LF320	20 A max
LF330	30 A max
LF340	40 A max

(4) CONNECTION TO MOTOR WITH BRAKE

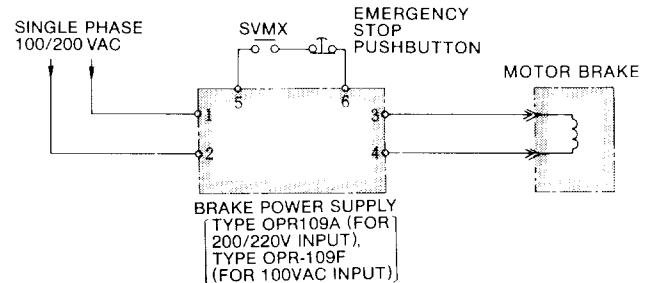

- Do not short-circuit output terminals 3 and 4.
- Tightly fasten terminal board screws.
- Protective devices are built-in. External protectors are not needed.
- The contact making and breaking current for terminals 5 and 6 shall be 5 to 10 times the rated current of the brake to be used. Use DC make-break contacts.

12. CONNECTION TO SPINDLE DRIVE UNIT (SDU)

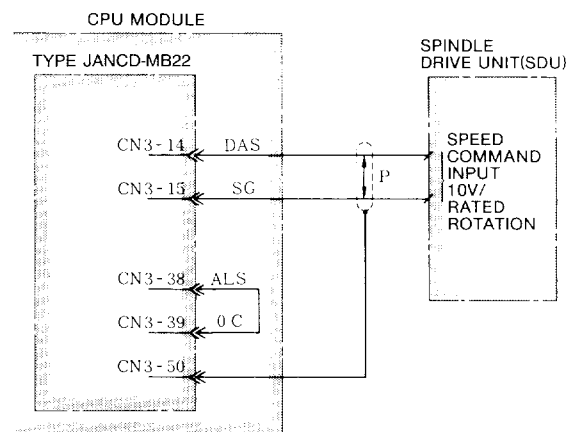

Note:

- The other signals of CN3 are the same as those of CN1 and CN2.
- The D/A converter specification on the YASNAC side is as follows.

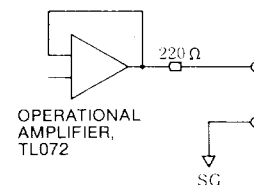
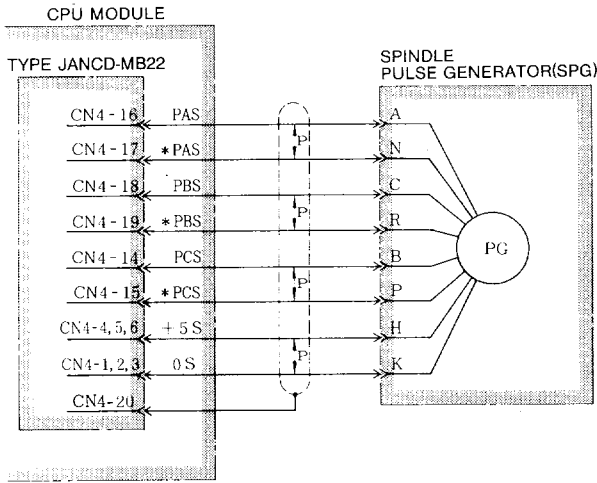

Fig. 12.1 Connecting Main Board (Type JANCD-MB20) to Spindle Drive Unit (SDU)

13. CONNECTION TO SPINDLE PULSE GENERATOR (SPG)



Note: The cable shield enclosure does not have to be grounded outside.

Fig. 13.1 Connecting Main Board (Type JANCD-MB22) to Spindle Pulse Generator (SPG)

14. CONNECTION TO RS-232C INTERFACE

14.1 CONNECTION

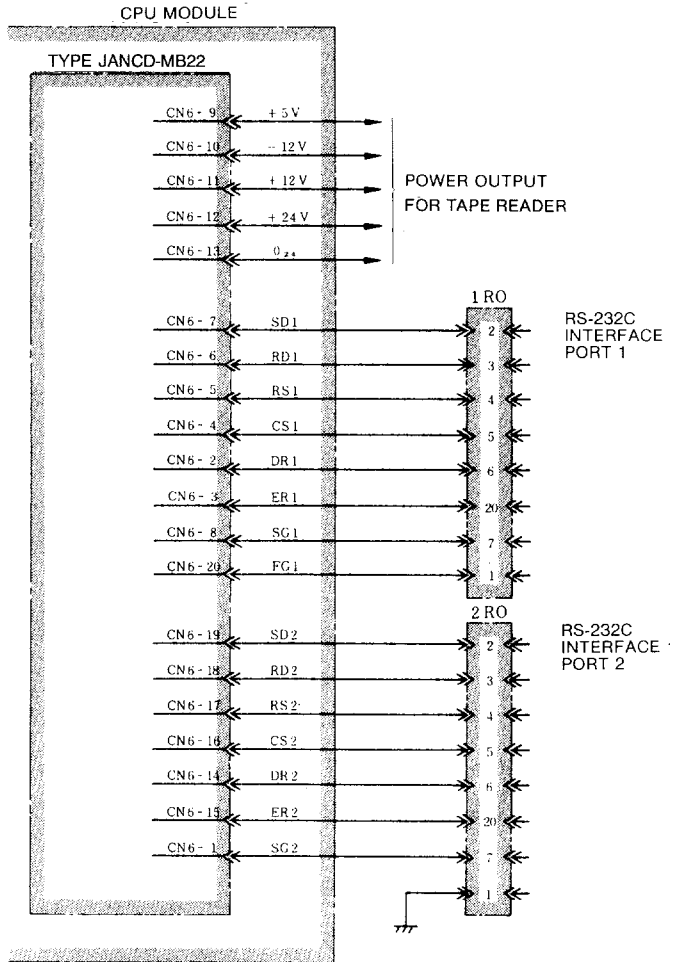

Note:

1. Use RS-232C interface to connect a separate type tape reader (PTR). Connect the tape reader as follows.

Example of RS-232C Port 1

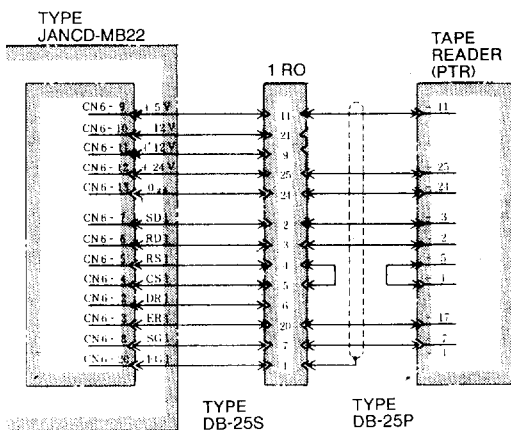

Fig. 14.1 Connecting RS-232C Interface to Main Board (Type JANCD-MB22)

2. The RS-232C interface port 1 must be used to connect a portable tape reader (PTR). Only the RS-232C interface port 2 can be freely selected by the customer.

The tape reader connection is the same as the above, however, when not using the RS-232C interface port 2, the IRO connector can be omitted from the connection.

3. The wiring distance between main board (type JANCD-MB22) and tape reader (PTR) should be less than 3 meters. If the distance exceeds 3 meters, contact your yaskawa representative.

14.2 RS-232C INTERFACE

(1) TRANSMISSION MODE

Start-stop synchronization: Each data bit is preceded by a start signal, and followed by a stop signal.

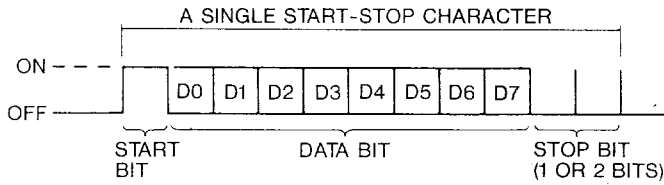

Table 14.1

	$V_0 < -3V$	$V_0 > +3V$
FUNCTION	OFF	ON
SIGNAL CONDITION	MARK	SPACE
LOGIC	1	0

(2) CODES USED

The following two types of codes are used, and are selectively used by parameters (#6026D5, #6028D5).

- EIA codes or ISO codes
- EIA codes or ISO codes + control codes (DC1 - DC4)

To use control codes, the machine to be controlled must be able to discriminate codes DC1 through DC4. Codes DC1 - DC4 are as follows.

Table 14.2

Character	8	7	6	5	4	Feed Hole	3	2	1
DC1 Tape reader start				○					○
DC2 Tape reader punching				○				○	
DC3 Tape reader stop	○			○				○	○
DC4 Tape punch release				○			○		

(3) TRANSMISSION BAUD RATE

Transmission Baud rates can be selected at any rate between 50 and 9600 Bauds with parameters. Refer to (7) in par. 14.2.

(4) CABLE LENGTH

The permissible maximum cable length varies with the machine to be controlled. Refer to the manual of the machine builder's manual. (Standard maximum cable length is 15 m.)

(5) INTERCONNECTION

Table 14.3 RS-232C Interface Connecting Cable (A)

NC (DB-25P)			Connections	External Equipment
Symbol	Signal Name	Pin No.		Symbol
FG	Frame grounding	1	○—○	FG
SD	Sending data	2	○—○	SD
RD	Receiving data	3	○—○	RD
RS	Sending data	4	○—○	RS
CS	Capable of sending	5	○—○	CS
DR	Data set ready	6	○—○	DR
SG	Signal grounding	7	○—○	SG
ER	Data terminal ready	20	○—○	IO BUSY
			○—○	ER

NC outputs control codes DC1 - DC4 to start and stop the machine, but the machine can not output control codes to control the NC. However, when the machine under control is unable to process data in time, it can control the CS signals of the NC to halt the data outputting of the NC.

When CS signals of the NC are not used, short CS and RS as shown Table 14.4.

Table 14.4 RS-232C Interface Connecting Cable (B)

NC (DB-25P)			Connections	External Equipment
Symbol	Signal Name	Pin No.		Symbol
FG	Frame grounding	1	○—○	FG
SD	Sending data	2	○—○	SD
RD	Receiving data	3	○—○	RD
RS	Sending data	4	○—○	RS
CS	Capable of sending	5	○—○	CS
DR	Data set ready	6	○—○	DR
SG	Signal grounding	7	○—○	SG
ER	Data terminal ready	20	○—○	ER (OR IO ALARM)

- Description of signals

FG: Safety grounding

SD: Transmission data (output)

RD: Received data (input)

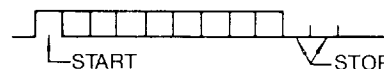

RS: Request for sending (output) - When sending data, NC is turned on when starting transmission, and turned off when transmission ends.

CS: For sending (input) - When this input signal is on, NC can send data. If the machine under control is unable to process data in time, it can turn off this signal to interrupt the transmission of data from NC within 2 characters. When this signal is not used, connect lines as shown in Table 14.4.

SG: Signal grounding.

ER: Data terminal ready - Use this signal as a tape rewinding signal if a tape reader is connected to an RS-232C interface. The tape reader can be rewound if this signal is ON.

NOTE

Among the RS-232C interface signals, the following are normally not used by the NC.

- DR: Data set ready
- ER: Data terminal ready
- CD: Data receiving carrier detection

However, when "1" is set for parameter CHKDR (#6021 D4), a DR (data set ready) interlock is added.

(6) SIGNAL EXCHANGE TIMING

• When NC receives data.

Data can be received in the following sequence and timing.

- (a) NC sends code DC1.
- (b) At code DC1, the machine under control starts to send data to NC.
- (c) If the NC can not process data in time, it sends out code DC3.
- (d) At code DC3, the machine stops sending data within 10 characters.
- (e) NC again sends code DC1 after processing data.
- (f) At code DC1, the machine sends out the data that succeeds the previously sent one.
- (g) Upon reading in the data, NC sends out code DC3.
- (h) The machine stops sending data.

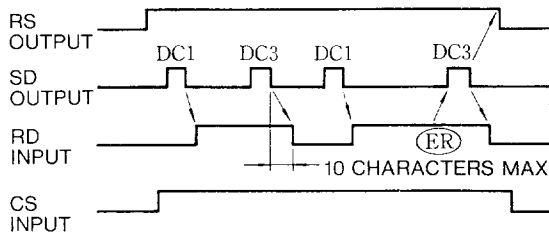

Fig. 14.2

• When NC sends out data

NC sends out data in the following sequence and timing.

- (a) NC sends out code DC2, and subsequently sends out data.
- (b) If the machine under control can not process the data in time, NC stops CS at no IO BUSY signal.
- (c) Upon completion of the data processing by the machine, NC turns on CS. NC sends out data that succeeds the previous one.
- (d) Upon completion of data sending, NC sends out code DC4.

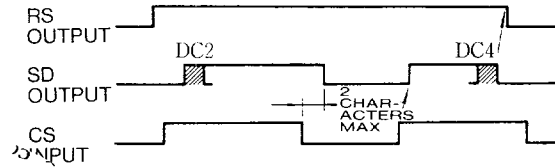

Fig. 14.3

NOTE

DC1 and DC3 code from RD is not available when NC sends out data.

(7) PARAMETER SETTING

When using RS-232C, set data transmission Baud rates, stop bit lengths, and control code sending specifications with the parameters shown in Tables 14.6 and 14.7.

- (a) RS-232C interface port selection

Select the RS-232C interface port by setting #6003. RS-232C ports 1 and 2 cannot be selected simultaneously.

Table 14.5 RS-232C Interface Port Selection

Interface	Input	Output
RS-232C Port 1	# 6003D ₀	# 6003D ₄
RS-232C Port 2	# 6003D ₁	# 6003D ₅

Note: The above bit is selected at parameter setting "1."

- (b) RS-232C interface port 1

Baud rate setting of RS-232C interface port 1 is shown in Table 14.6.

Table 14.6 Baud Rate Setting

Input	# 6026D3	# 6026D2	# 6026D1	# 6026D0
Output	# 6028D3	# 6028D2	# 6028D1	# 6028D0
Baud Rate Values	50	0	0	0
	100	0	0	1
	110	0	0	1
	150	0	0	1
	200	0	1	0
	300	0	1	0
	600	0	1	1
	1200	0	1	1
	2400	1	0	0
	4800	1	0	0
9600	1	0	1	

14.2 RS-232C INTERFACE (Cont'd)

- Stop bit length setting
 - #6026 D4 for input 1: Sets stop bit at two bits.
 - #6028 D4 for output 0: Sets stop bit at one bit.
- Setting of control code sending
 - #6026 D5 for input 1: Does not send control code.
 - #6028 D5 for output 0: Sends control code.

(c) RS-232C interface port 2

Baud rate setting of RS-232C interface port 2 is shown in Table 14.7.

Table 14.7

Input	# 6027 D3	# 6027 D2	# 6027 D1	# 6027 D0
Output	# 6029 D3	# 6029 D2	# 6029 D1	# 6029 D0
Baud Rate Values	50	0	0	0
	100	0	0	1
	110	0	0	1
	150	0	0	1
	200	0	1	0
	300	0	1	0
	600	0	1	1
	1200	0	1	1
	2400	1	0	0
	4800	1	0	0
9600	1	0	1	

Stop bit length setting

- #6027 D4 for input 1: Sets stop bit at two bits.
- #6029 D4 for output 0: Sets stop bit at one bit.

• Setting of control code sending

- #6027 D5 for 1: does not send control code.
- #6029 D5 for 0: Sends control code.

NOTE

Baud rate value defined by setting means bit transfer rate of 1 character. Especially using 9600 baud rate, each character needs idle time over 1 character transmitting time.

15. DIRECT-IN SIGNAL CONNECTION

The following input signals require high-speed processing and are connected to the main board (type JANCD-MB20), instead of general-purpose I/O boards.

These signals are processed directly by the NC main processing unit without coursing through the PC.

- DIN0: Skip input
- DIN1: Spare
- DIN2: Spare

DIN3: Spare

Direct-in signal connection is shown in Figs. 15.1 and 15.2.

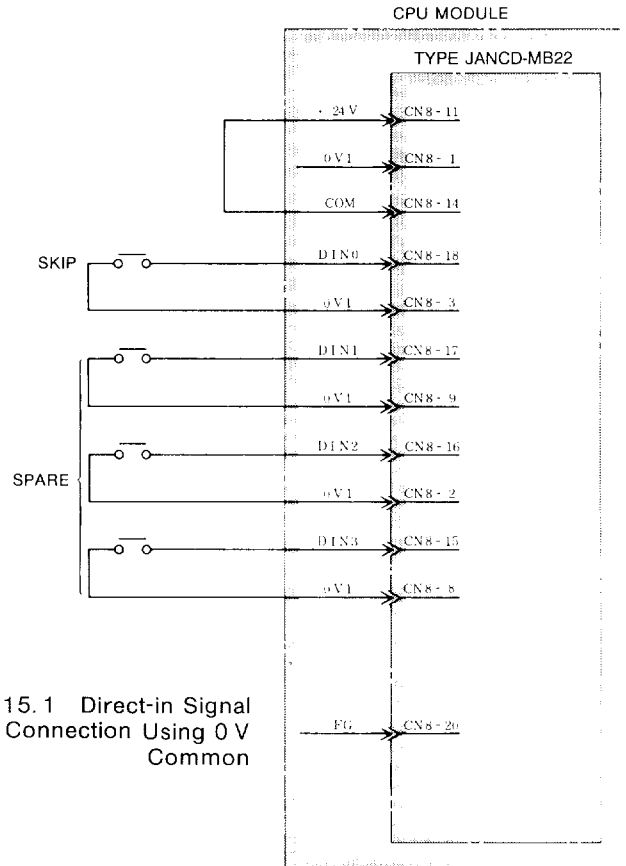

Fig. 15.1 Direct-in Signal Connection Using 0 V Common

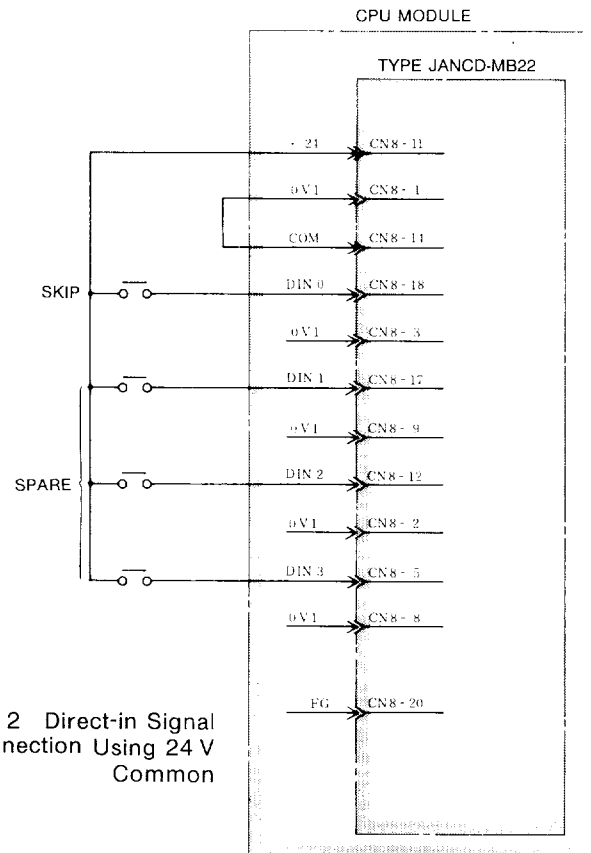

Fig. 15.2 Direct-in Signal Connection Using 24 V Common

16. CONNECTION TO GENERAL-PURPOSE I/O SIGNALS

16.1 I/O PORTS

(1) The YASNAC LX3 contains the programmable controller system (PC). External signals can be allocated to its I/O ports freely when the machine manufacturer designs a built-in PC. For details, refer to Instruction Manual for YASNAC LX3/MX3 PC System (TOE-C843-9.1).

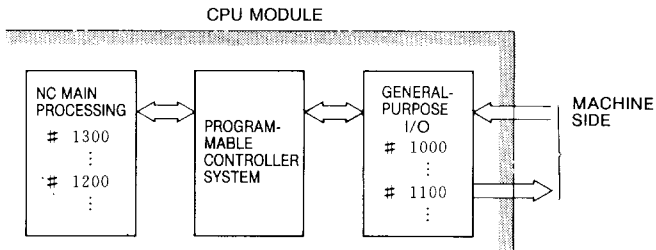

Fig. 16.1 System Configuration

(2) The general-purpose I/O ports are mounted on the I/O board type JANCD-IO20 of the CPU module and on the SP20 board of the CRT operator's panel.

The numbers of I/O points of these boards are shown in Table 16.1.

Table 16.1 Numbers of I/O Points of Boards

Baud Type JANCD-	Input Points	Output Points	Remarks
IO20-01	48	48	Select any one.
IO20-02	88	48	
IO20-03	112	64	
SP20-02	64	32	For machine panels (option)

I/O board and I/O ports mounted on it are shown in Table 16.2.

Table 16.2 I/O Board (Type JANCD-IO20) and Mounted I/O Ports (for Module No. 1)

Connector	Input	Output	I/O Board Type JANCD-												
			IO20-01	IO20-02	IO20-03										
CN51	-	# 1100	○	○	○										
		# 1101													
		# 1102													
		# 1103													
		# 1104													
CN52	# 1013	# 1105	○	○	○										
		# 1106	-	-	○										
		# 1107													
CN53	# 1010 # 1011 # 1012	-	-	○	○										
						# 1000 # 1001 # 1002 # 1003 # 1004	-	-	○	○					
											# 1005 # 1006 # 1007 # 1008 # 1009	-	○	○	○

○: I/O ports mounted.

16.2 I/O CIRCUITS OF I/O PORTS

16.2.1 I/O BOARD TYPE JANCD-IO20 (HEREAFTER CALLED IO20)

(1) Input Circuits

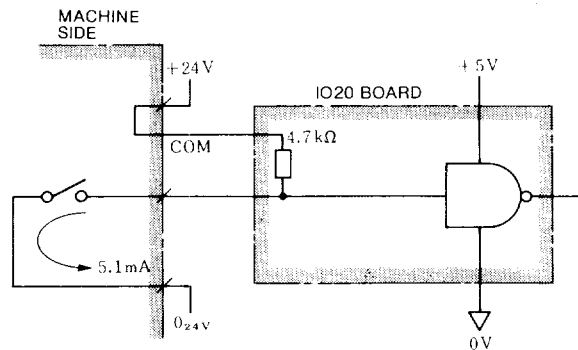

(a) 0 V Common

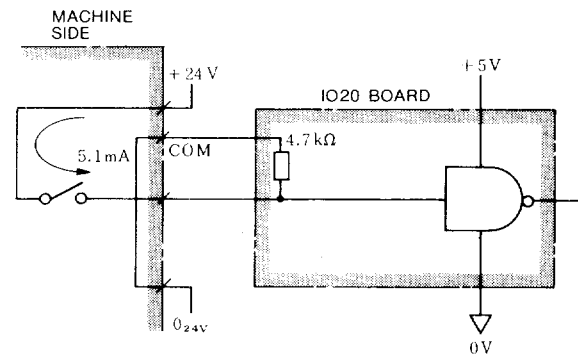

(b) +24 V Common

Note:

- "Common" in the input circuit (for example, COM10, COM20, COM21 ... total 9) can be either "+24 V common" or "0V common" for every 8 or 16 input points as mentioned in par. 17.3 I/O signal interface and can be selected freely. Set by wiring on the cable side. By turning on the switch as shown above, 5.1 mA will be consumed.
- Input voltage levels and logics are as follows:

Logic	Input Voltage Level
0	6.9V max
1	19.2V min.

Fig. 16.2 Input Circuits

16.2.1 I/O BOARD TYPE JANCD-IO20
(HEREAFTER CALLED IO20) (Cont'd)

(2) Output Circuits

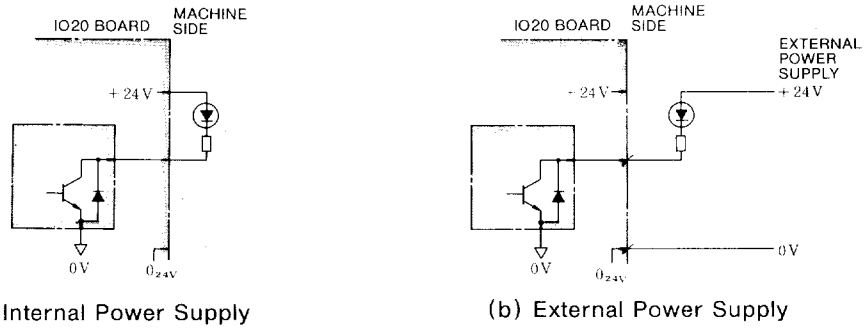

(a) Internal Power Supply

(b) External Power Supply

Note:

1. All 64 output points are transistor open-collector outputs. The current when ON should be maximum 70 mA per circuit.
2. The maximum current consumption for the entire output circuit including SP20 should be 0.5A or less if LEDs, etc. are to be driven using internal power supply (+24V).
3. The output transistor may break if the input and output connector are connected incorrectly.
4. Internal power supply (+24V) not allowed to drive the all output circuit.

Following usages are recommended.

Input	SP20	} Internal Power Supply
	IO20	
Output	SP20	} External Power Supply
	IO20	

Fig. 16.3 Output Circuits

16.2.2 I/O BOARD TYPE JANCD-SP20
(HEREAFTER CALLED SP20)

(1) Input Circuits

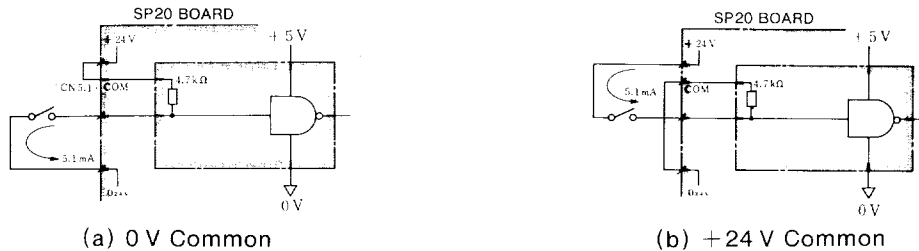

(a) 0V Common

(b) +24V Common

Note: Make switching of 0V common and +24V common by connector (CN5-1) wiring.

Fig. 16.4 Input Circuits

(2) Output Circuits

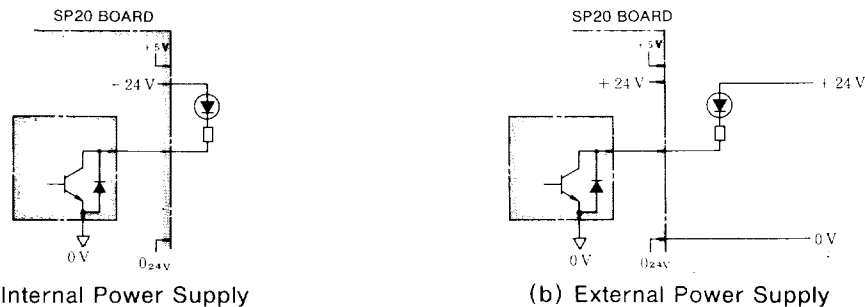

(a) Internal Power Supply

(b) External Power Supply

Note:

1. All 32 output points are polarized contactless (transistorized open collector) outputs. The current when ON should be maximum 70 mA per circuit.
2. Normally use +24V, even though +5V is also available, to drive LEDs, etc. using internal power supply.
 - +5V output — 0.5 A max including 150 mA for HPG power supply
 - Output connector — CN1 to CN7 (+5V)
CN1 to CN13(05)
3. The output transistor may break if the connectors for CN4 and CN 5 are connected incorrectly.

Fig. 16.5 Output Circuits

16.3 I/O SIGNAL INTERFACE

16.3.1 I/O 20 BOARDS

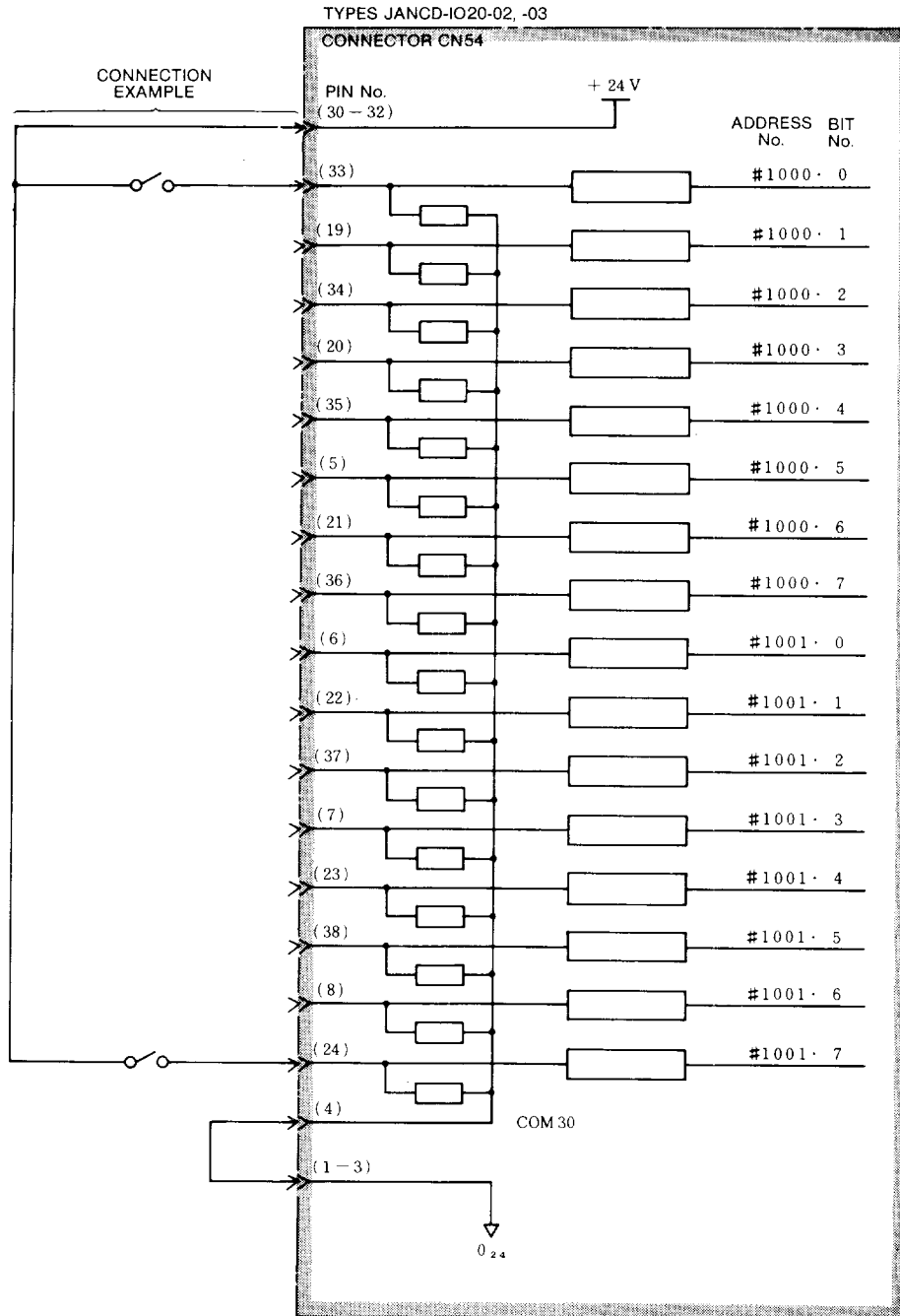

Note:

1. This connection example shows +24 V common. 0 V common is also available. Refer to par. 16.2.1, I/O Board Type JANCD-IO20 for connection details.
2. The addresses are those for module No. 1. The address layouts for modules Nos. 2 to 4 are the same as shown above starting with newer addresses. Refer to Appendix B(3), Address Classification for details.

Fig. 16.6 Connection to Address and Bit Nos. #1000.0 to #1001.7 on IO 20 Board

16.3.1 I/O 20 BOARDS (Cont'd)

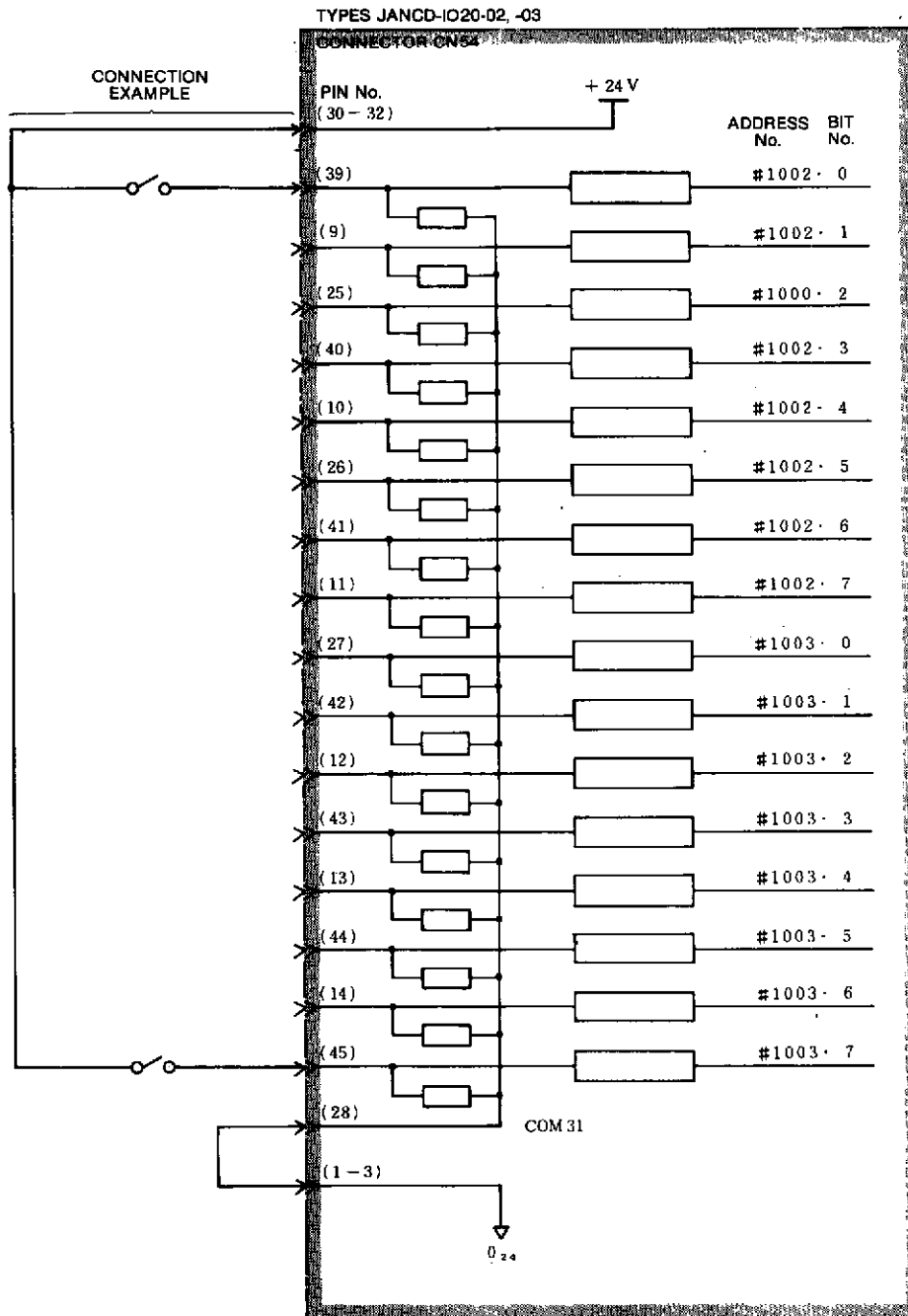

Note:

1. This connection example shows +24 V common. 0 V common is also available. Refer to par. 16.2.1, I/O Board Type JANCD-IO20 for connection details.
2. The addresses are those for module No. 1. (#1002.0 to #1003.7). The address layouts for modules Nos. 2 to 4 are the same as shown above starting with newer addresses. Refer to Appendix B(3), Address Classification for details.

Fig. 16.7 Connection to Address and Bit Nos. #1002.0 to #1003.7 on IO 20 Board

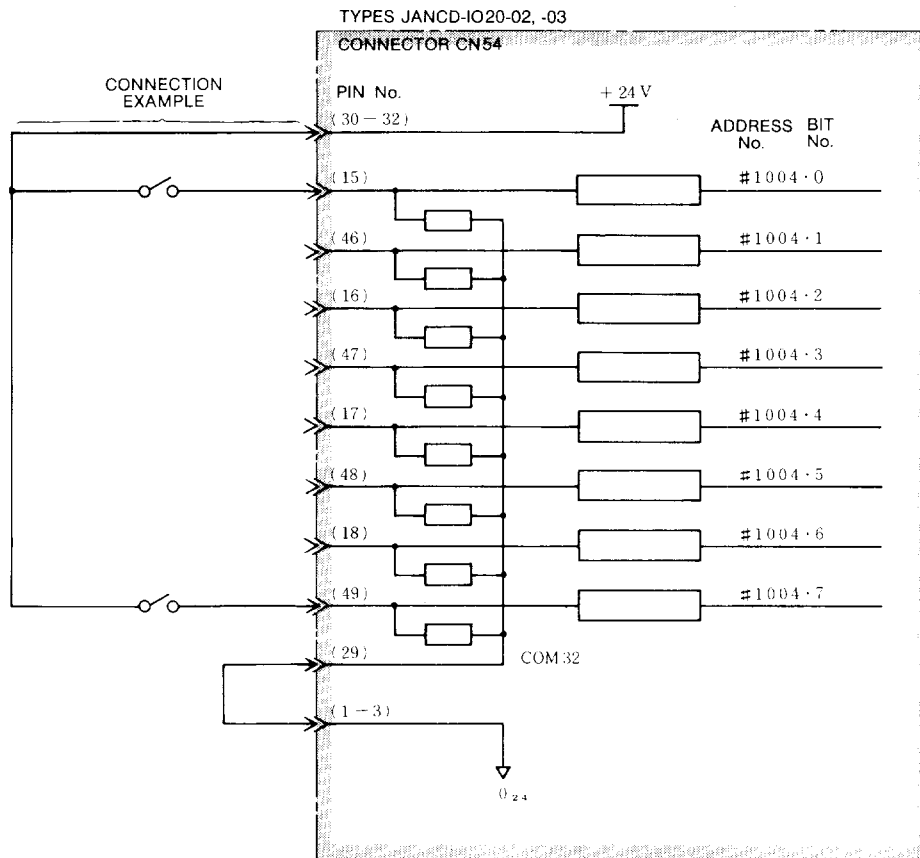

Note:

1. This connection example shows +24 V common. 0 V common is also available. Refer to par. 16.2.1, I/O Board Type JANCD-IO20 for connection details.
2. The addresses are those for module No. 1. (#1004.0 to #1004.7). The address layouts for modules Nos. 2 to 4 are the same as shown above starting with newer addresses. Refer to Appendix B (3), Address Classification for details.

Fig. 16.8 Connection to Address and Bit Nos. #1004.0 to #1004.7 on IO 20 Board

16.3.1 I/O 20 BOARDS (Cont'd)

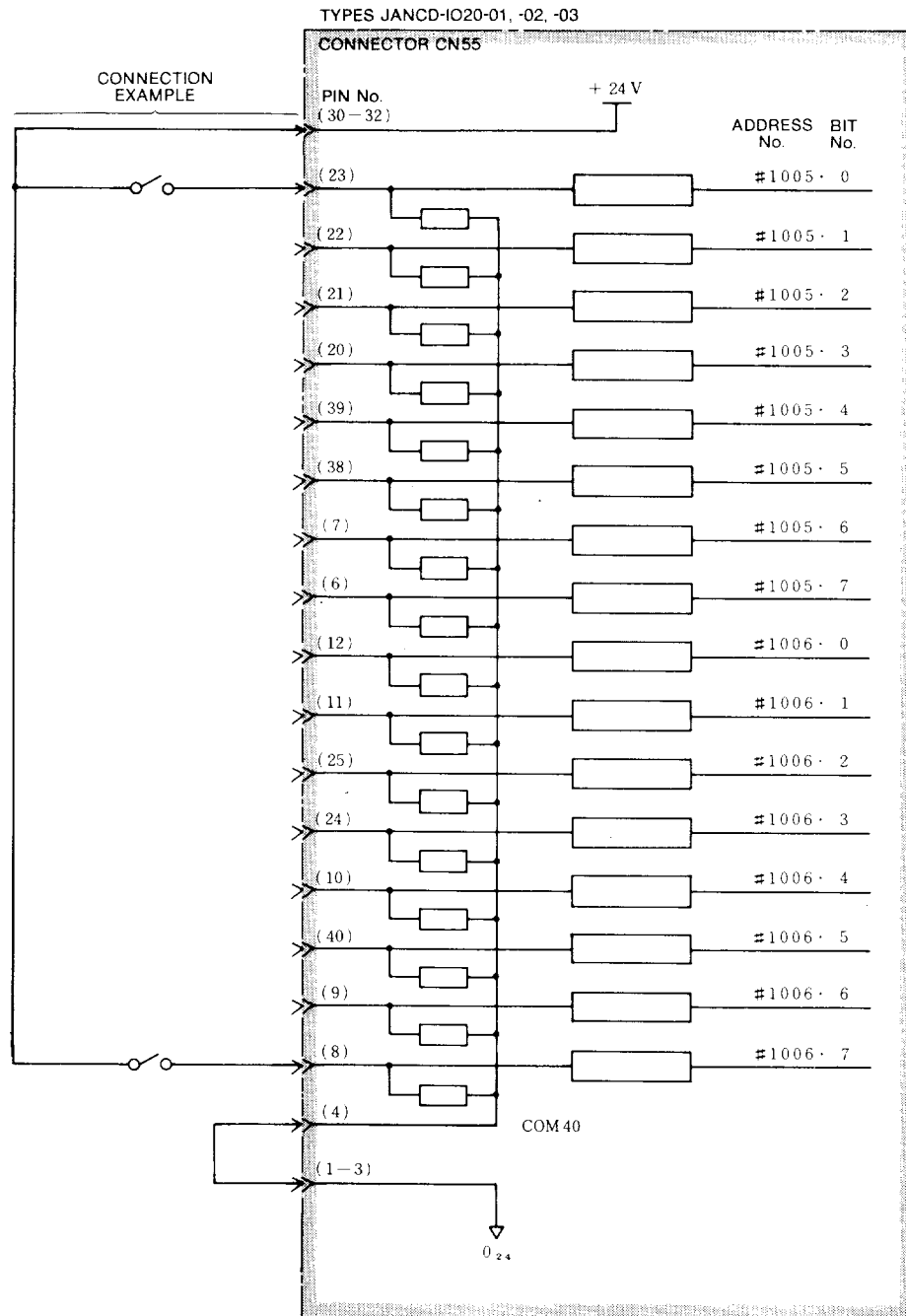

Note:

1. This connection example shows +24 V common. 0 V common is also available. Refer to par. 16.2.1, I/O Board Type JANCD-IO20 for connection details.
2. The addresses are those for module No. 1. (#1005.0 to #1006.7). The address layouts for modules Nos. 2 to 4 are the same as shown above starting with newer addresses. Refer to Appendix B(3), Address Classification for details.

Fig. 16.9 Connection to Address and Bit Nos. #1005.0 to #1006.7 on IO 20 Board

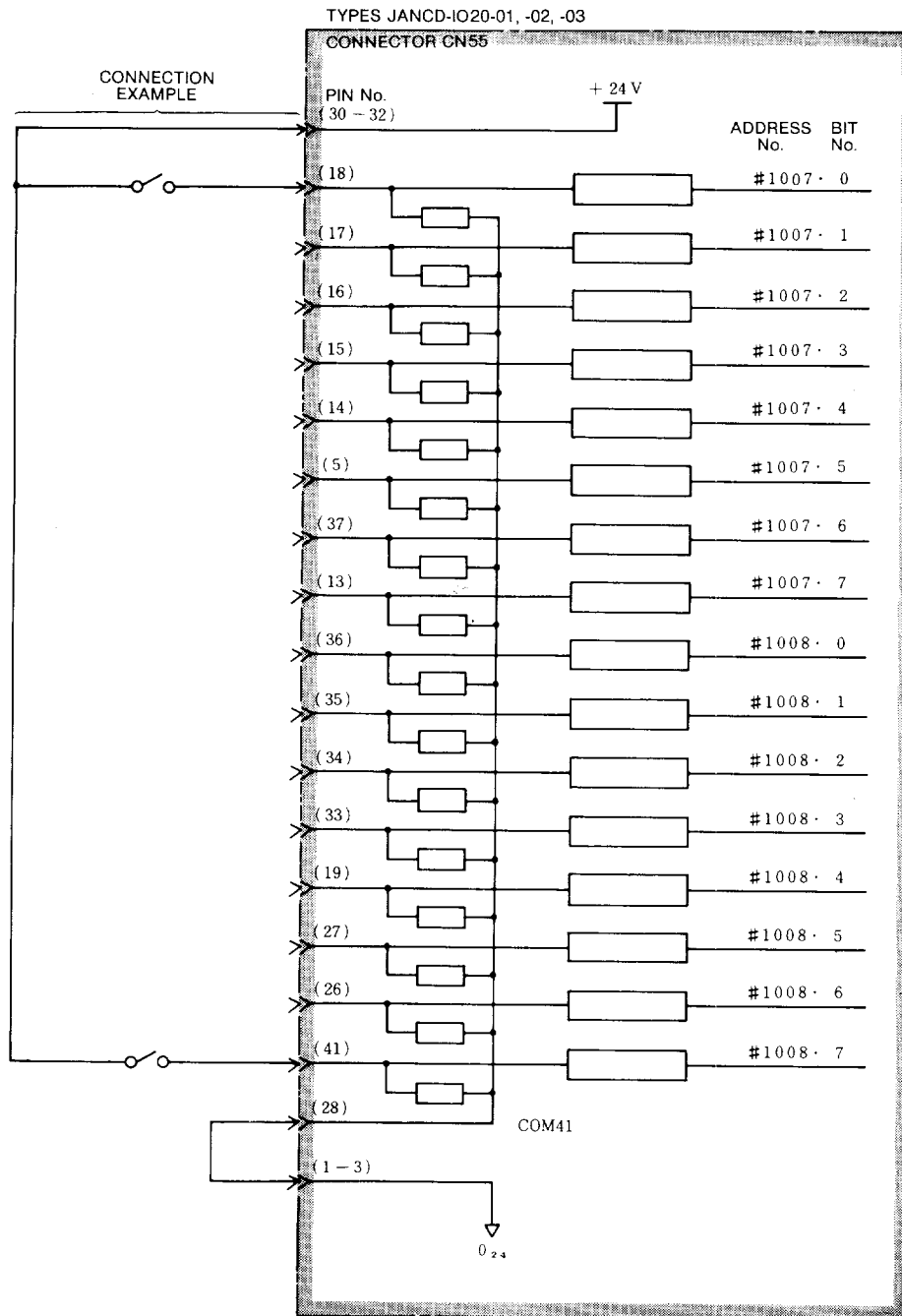

Note:

1. This connection example shows +24 V common. 0 V common is also available. Refer to par.16.2.1, I/O Board Type JANCD-IO20 for connection details.
2. The addresses are those for module No. 1. (#1007.0 to #1008.7). The address layouts for modules Nos. 2 to 4 are the same as shown above starting with newer addresses. Refer to Appendix B(3), Address Classification for details.

Fig. 16.10 Connection to Address and Bit Nos.
#1007.0 to #1008.7 on IO 20 Board

16.3.1 I/O 20 BOARDS (Cont'd)

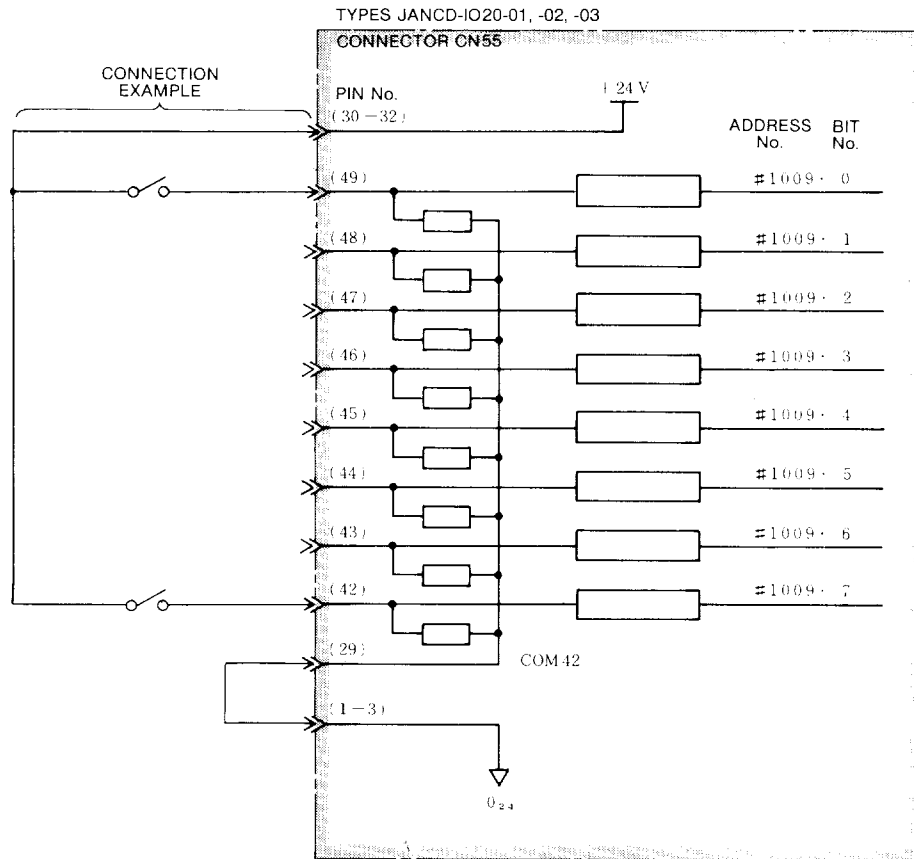

Note:

1. This connection example shows +24 V common. 0 V common is also available. Refer to par. 16.2.1, I/O Board Type JANCD-IO20 for connection details.
2. The addresses are those for module No. 1. (#1009.0 to #1009.7). The address layouts for modules Nos. 2 to 4 are the same as shown above starting with newer addresses. Refer to Appendix B(3), Address Classification for details.

Fig. 16.11 Connection to Address and Bit Nos. #1009.0 to #1009.7 on IO 20 Board

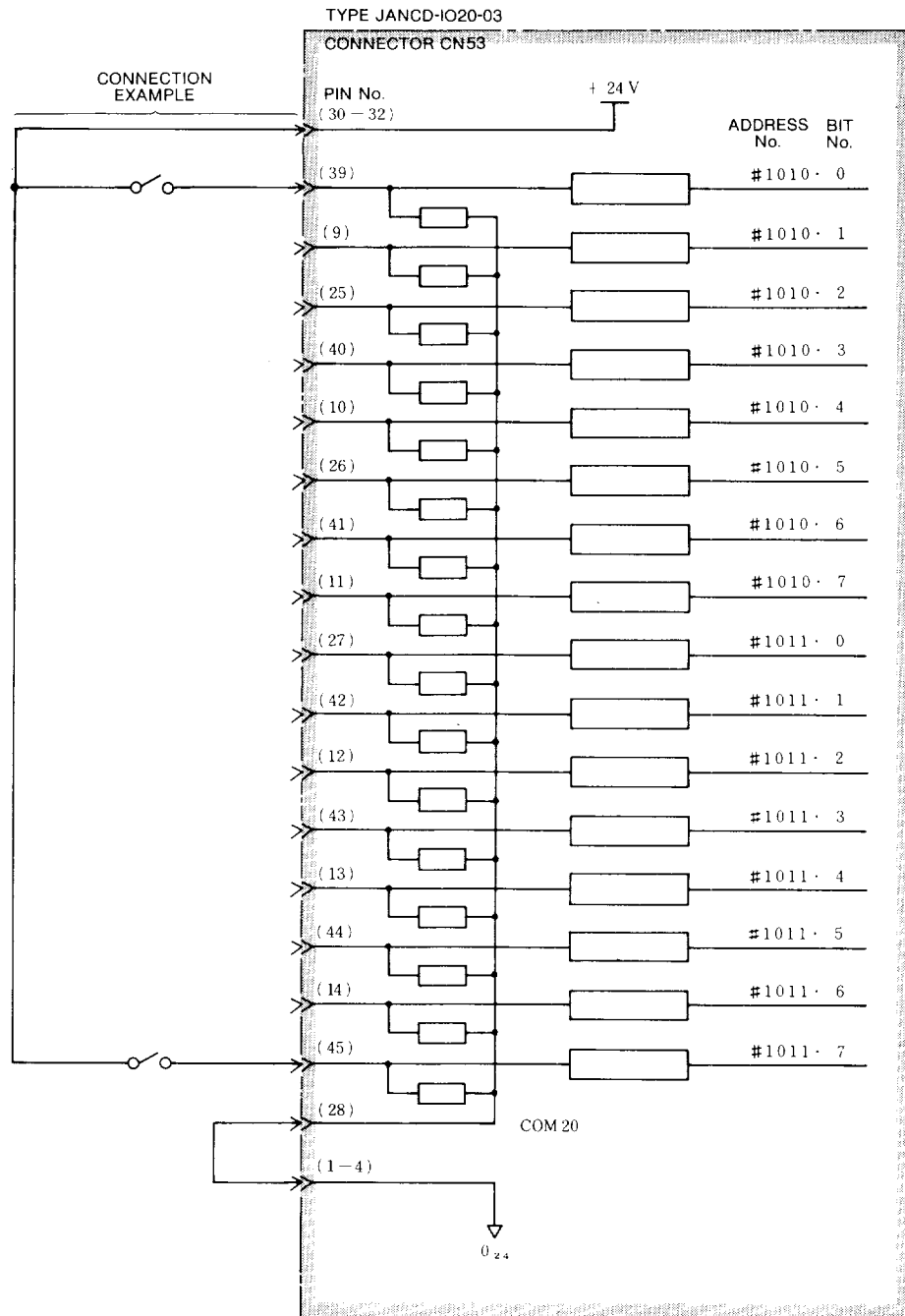

Note:

1. This connection example shows +24 V common.
0 V common is also available. Refer to par. 16.2.1, I/O Board Type JANCD-IO20 for connection details.
2. The addresses are those for module No. 1. (#1010.0 to #1011.7). The address layouts for modules Nos. 2 to 4 are the same as shown above starting with newer addresses. Refer to Appendix B(3), Address Classification for details.

Fig. 16.12 Connection to Address and Bit Nos.
#1010.0 to #1011.7 on IO 29 Board

16.3.1 I/O 20 BOARDS (Cont'd)

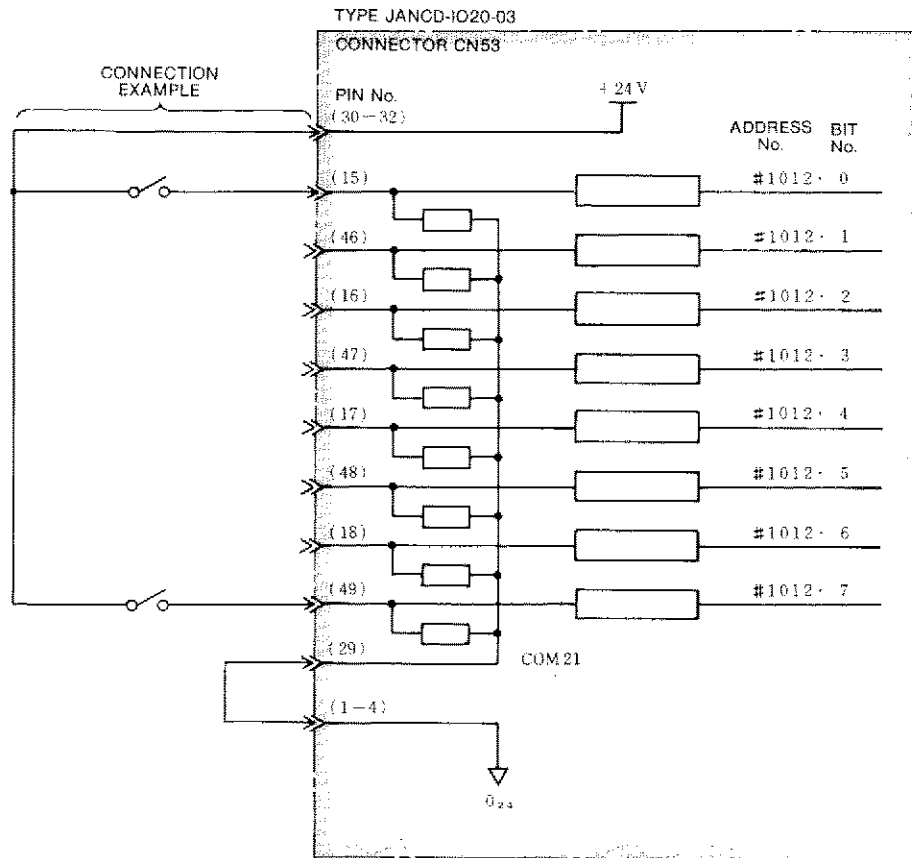

Note:

1. This connection example shows +24 V common. 0 V common is also available. Refer to par. 16.2.1, I/O Board Type JANCD-IO20 for connection details.
2. The addresses are those for module No. 1, (#1012.0 to #1012.7). The address layouts for modules Nos. 2 to 4 are the same as shown above starting with newer addresses. Refer to Appendix B(3), Address Classification for details.

Fig. 16.13 Connection to Address and Bit Nos. #1012.0 to #1012.7 on IO 20 Board

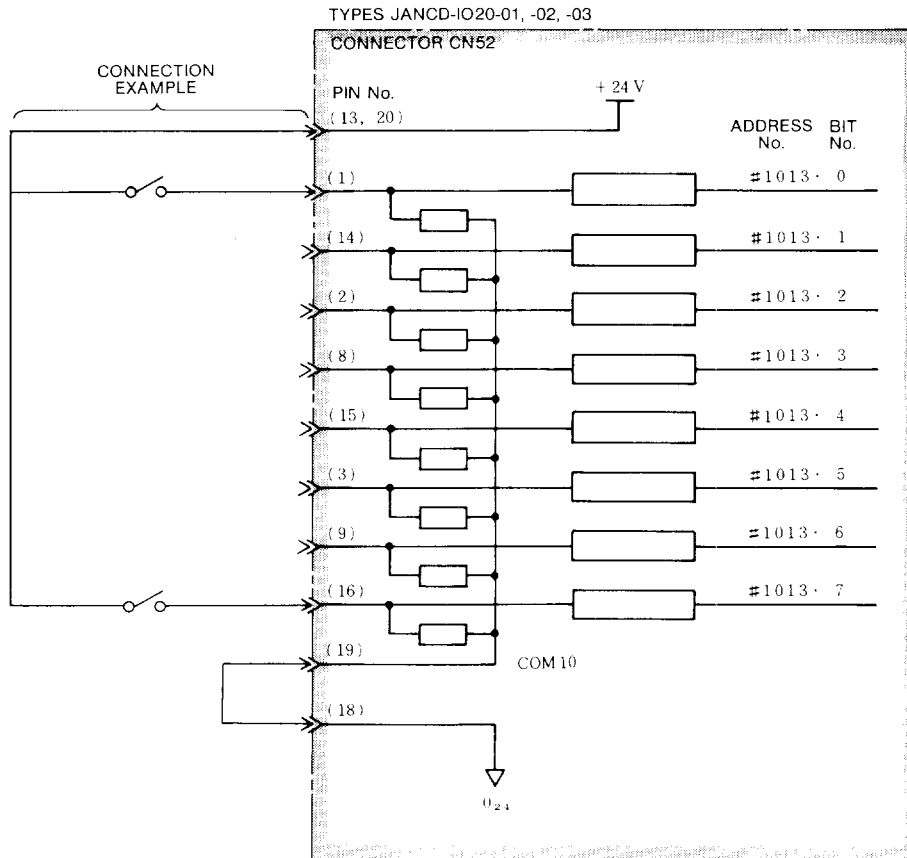

Note:

1. This connection example shows +24 V common. 0 V common is also available. Refer to par. 16.2.1, I/O Board Type JANCD-IO20 for connection details.
2. The addresses are those for module No. 1. (#1013.0 to #1013.7). The address layouts for modules Nos. 2 to 4 are the same as shown above starting with newer addresses. Refer to Appendix B(3), Address Classification for details.
3. Connector CN52 can be used conveniently for interface with the spindle drive unit.

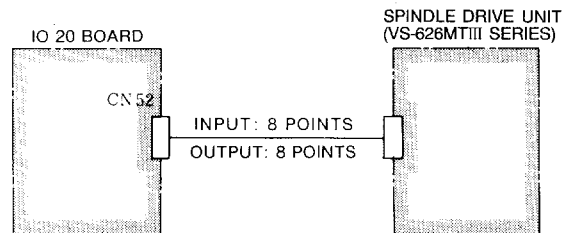
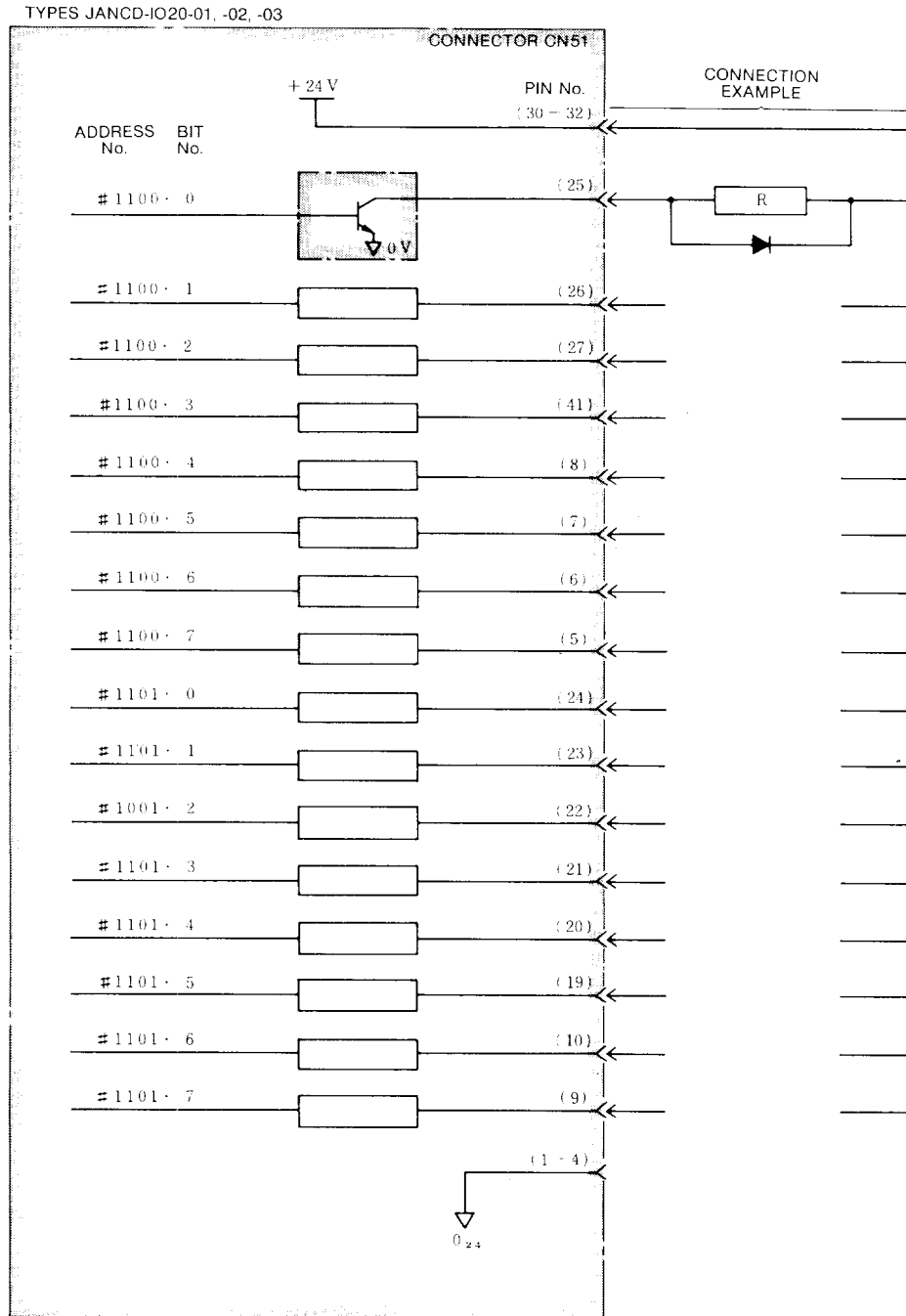

Fig. 16.14

16.3.1 I/O 20 BOARDS (Cont'd)



Note:

1. This connection example shows +24 V common. 0 V common is also available. Refer to par. 16.2.1, I/O Board Type JANCD-IO20 for connection details.
2. The addresses are those for module No. 1, (#1100.0 to #1101.7). The address layouts for modules Nos. 2 to 4 are the same as shown above starting with newer addresses. Refer to Appendix B, Address Classification for details.

Fig. 16.15 Connection to Address and Bit Nos. #1100.0 to #1101.7 on IO 20 Board

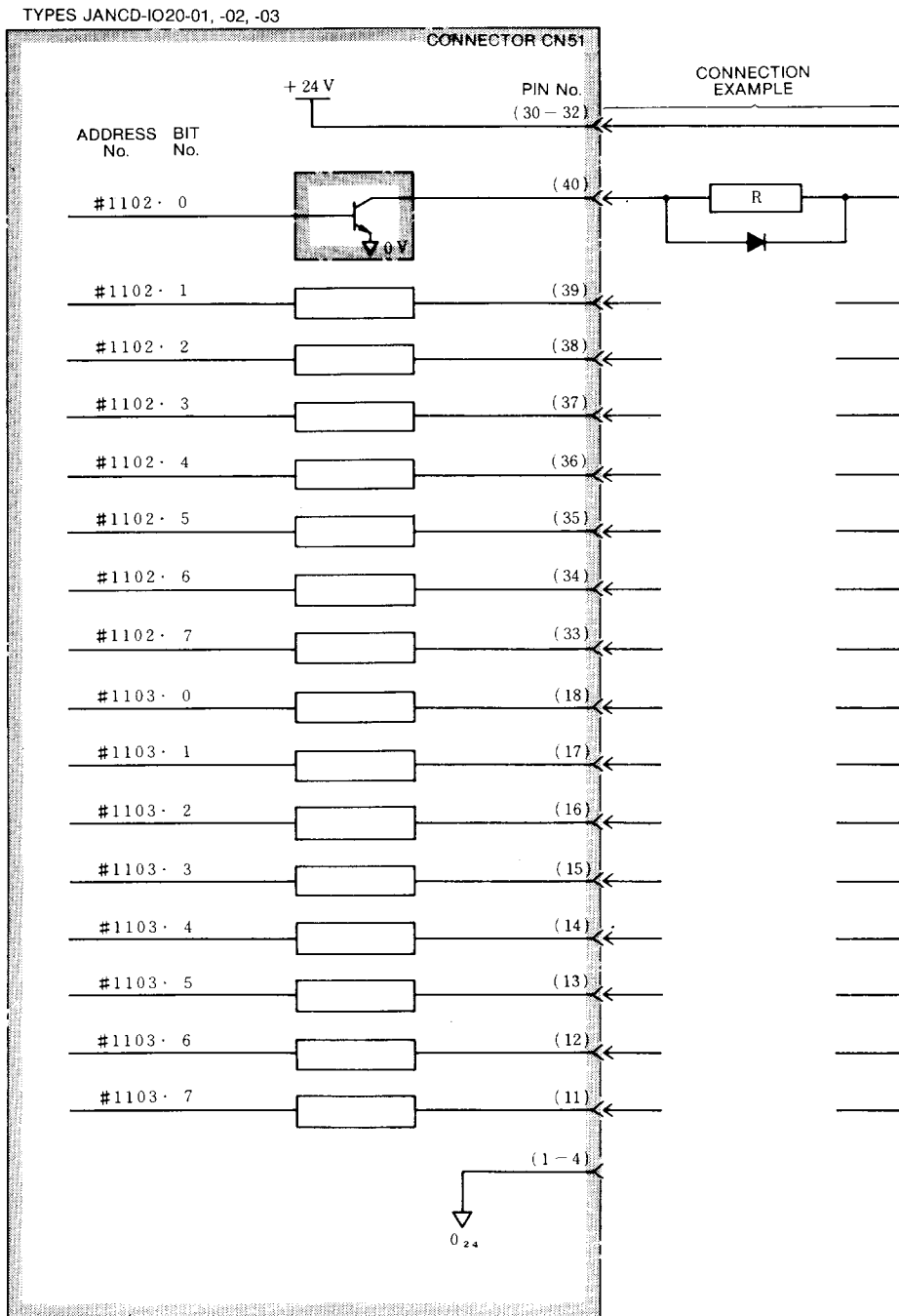

Note:

1. This connection example shows +24 V common. 0 V common is also available. Refer to par. 16.2.1, I/O Board Type JANCD-IO20 for connection details.
2. The addresses are those for module No. 1. (#1102.0 to #1103.7). The address layouts for modules Nos. 2 to 4 are the same as shown above starting with newer addresses. Refer to Appendix B(3), Address Classification for details.

Fig. 16.16 Connection to Address and Bit Nos. #1102.0 to #1103.7 on IO 20 Board

16.3.1 I/O 20 BOARDS (Cont'd)

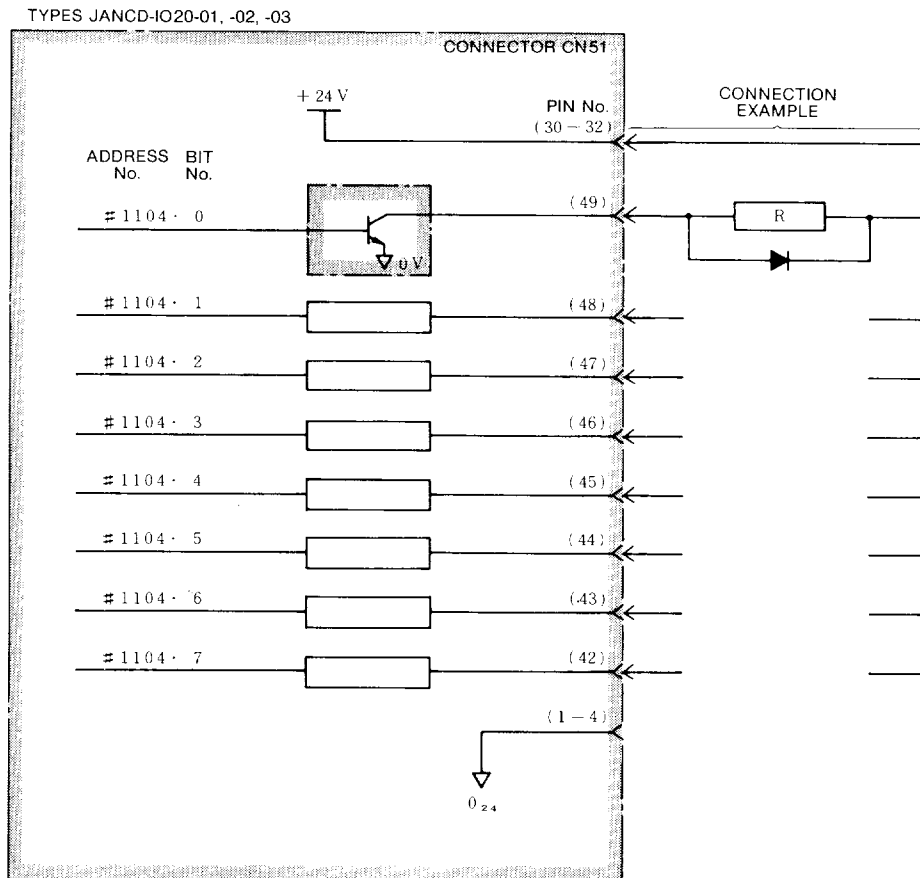

Note:

1. This connection example shows +24 V common. 0 V common is also available. Refer to par. 16.2.1, I/O Board Type JANCD-IO20 for connection details.
2. The addresses are those for module No. 1. (#1104.0 to #1104.7). The address layouts for modules Nos. 2 to 4 are the same as shown above starting with newer addresses. Refer to Appendix B(3), Address Classification for details.

Fig. 16.17 Connection to Address and Bit Nos. #1104.0 to #1104.7 on IO 20 Board

TYPES JANCD-IO20-01, -02, -03

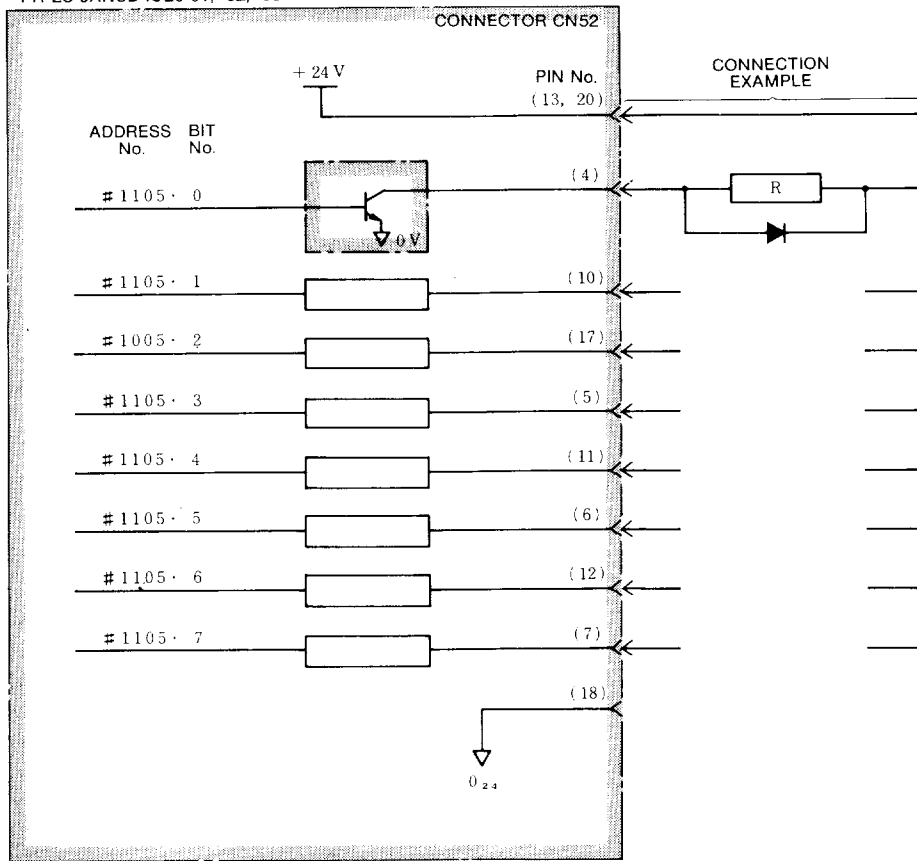

Note:

1. This connection example shows +24 V common. 0 V common is also available. Refer to par. 16.2.1, I/O Board Type JANCD-IO20 for connection details.
2. The addresses are those for module No. 1. (#1105.0 to #1105.7). The address layouts for modules Nos. 2 to 4 are the same as shown above starting with newer addresses. Refer to Appendix B(3), Address Classification for details.

Fig. 16.18 Connection to Address and Bit Nos. #1105.0 to #1105.7 on IO 20 Board

16.3.1 I/O 20 BOARDS (Cont'd)

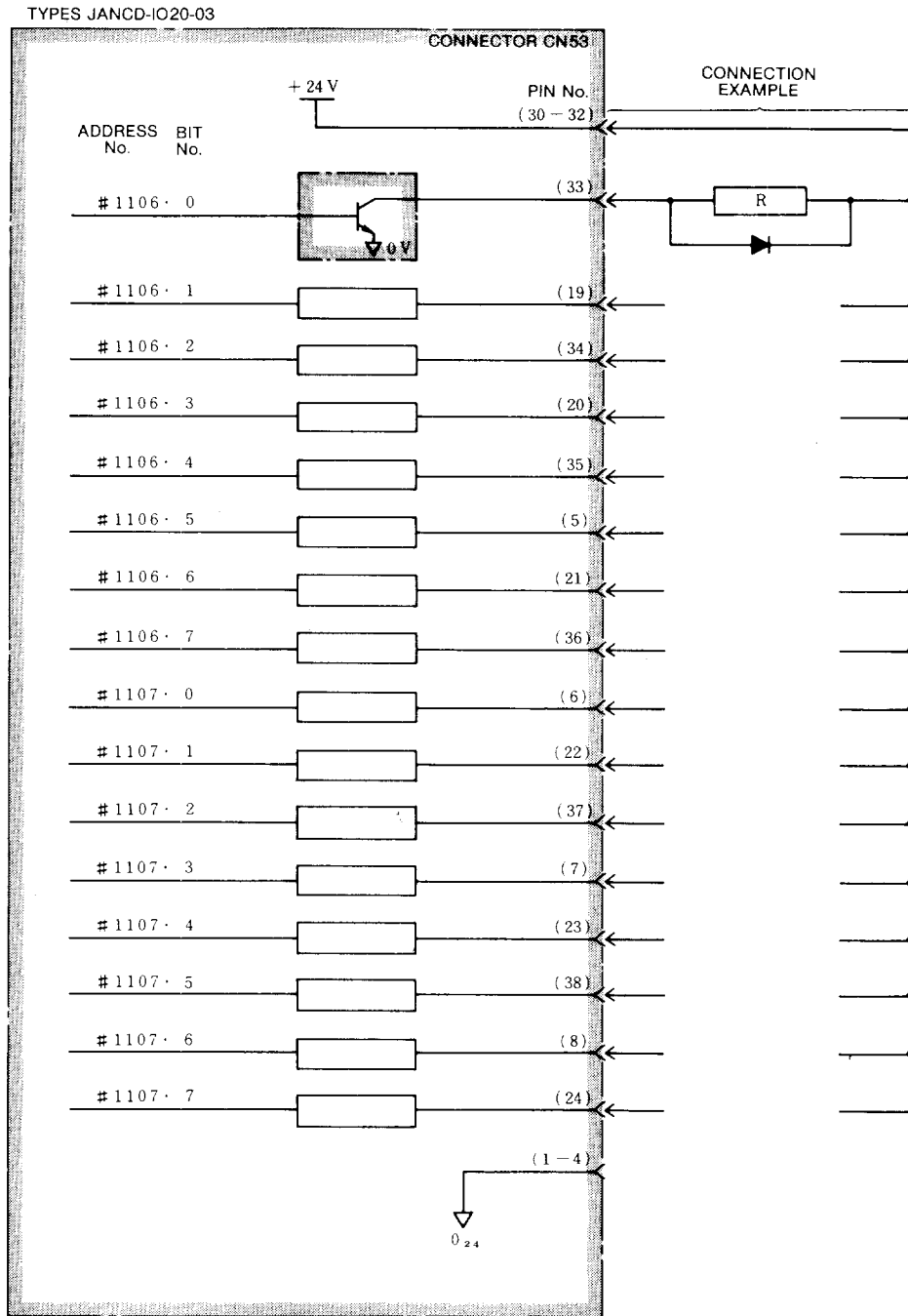

Note:

1. This connection example shows +24 V common. 0 V common is also available. Refer to par. 16.2.1, I/O Board Type JANCD-IO20 for connection details.
2. The addresses are those for module No. 1. (#1106.0 to #1107.7). The address layouts for modules Nos. 2 to 4 are the same as shown above starting with newer addresses. Refer to Appendix B(3), Address Classification for details.

Fig. 16.19 Connection to Address and Bit Nos. #1106.0 to #1107.7 on IO 20 Board

16.3.2 SP 20 BOARDS

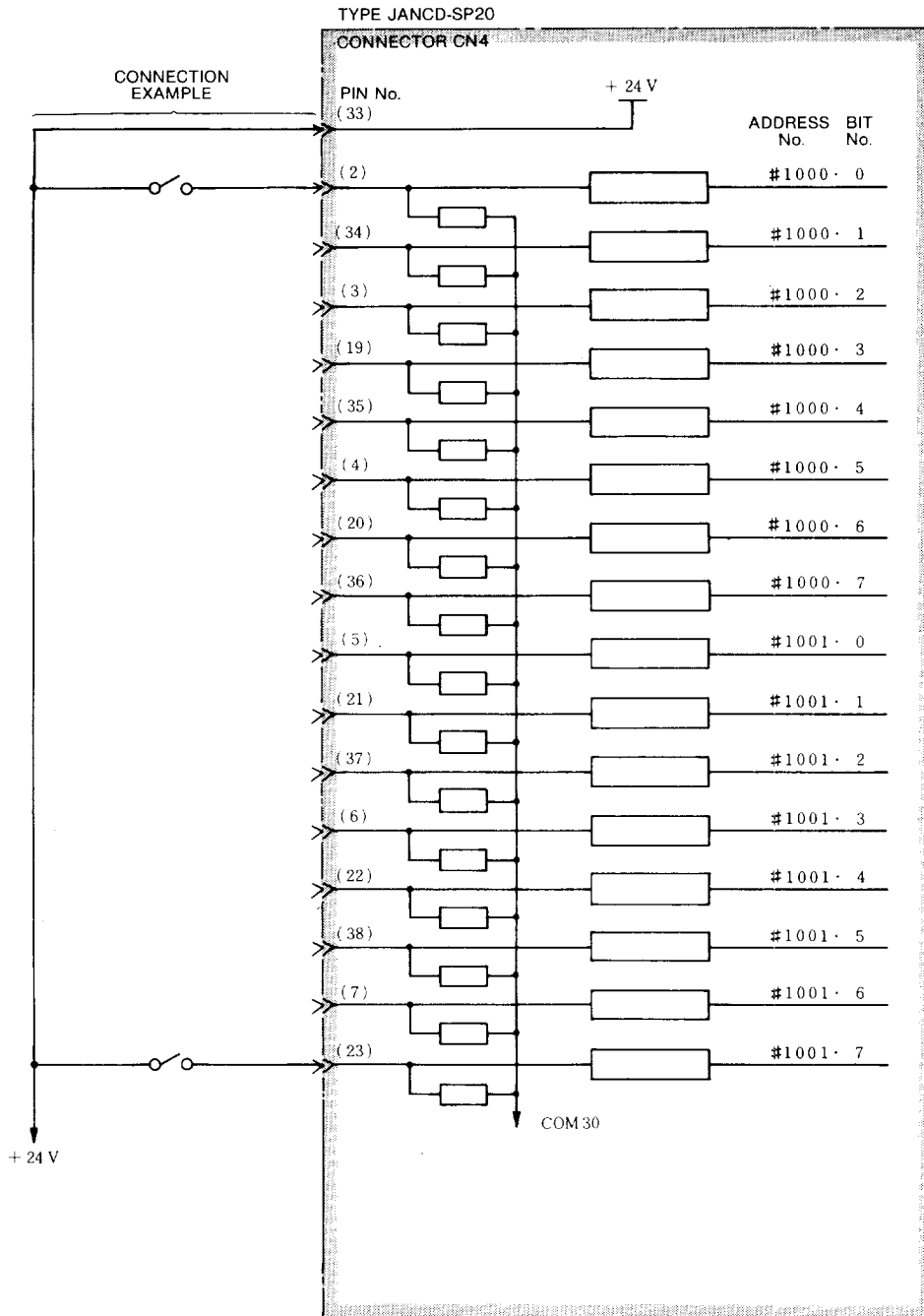

Note:

1. This connection example shows +24 V common. 0 V common is also available. Refer to par. 16.2.2, I/O Board Type JANCD-SP20 for connection details.
2. The addresses are those for module No. 1. (#1000.0 to #1001.7). The address layouts for modules Nos. 2 to 4 are the same as shown above starting with newer addresses. Refer to Appendix B(3), Address Classification for details.

Fig. 16.20 Connection of Address and Bit Nos. #1000.0 to #1001.7 on SP 20 Board

16.3.2 SP 20 BOARDS (Cont'd)

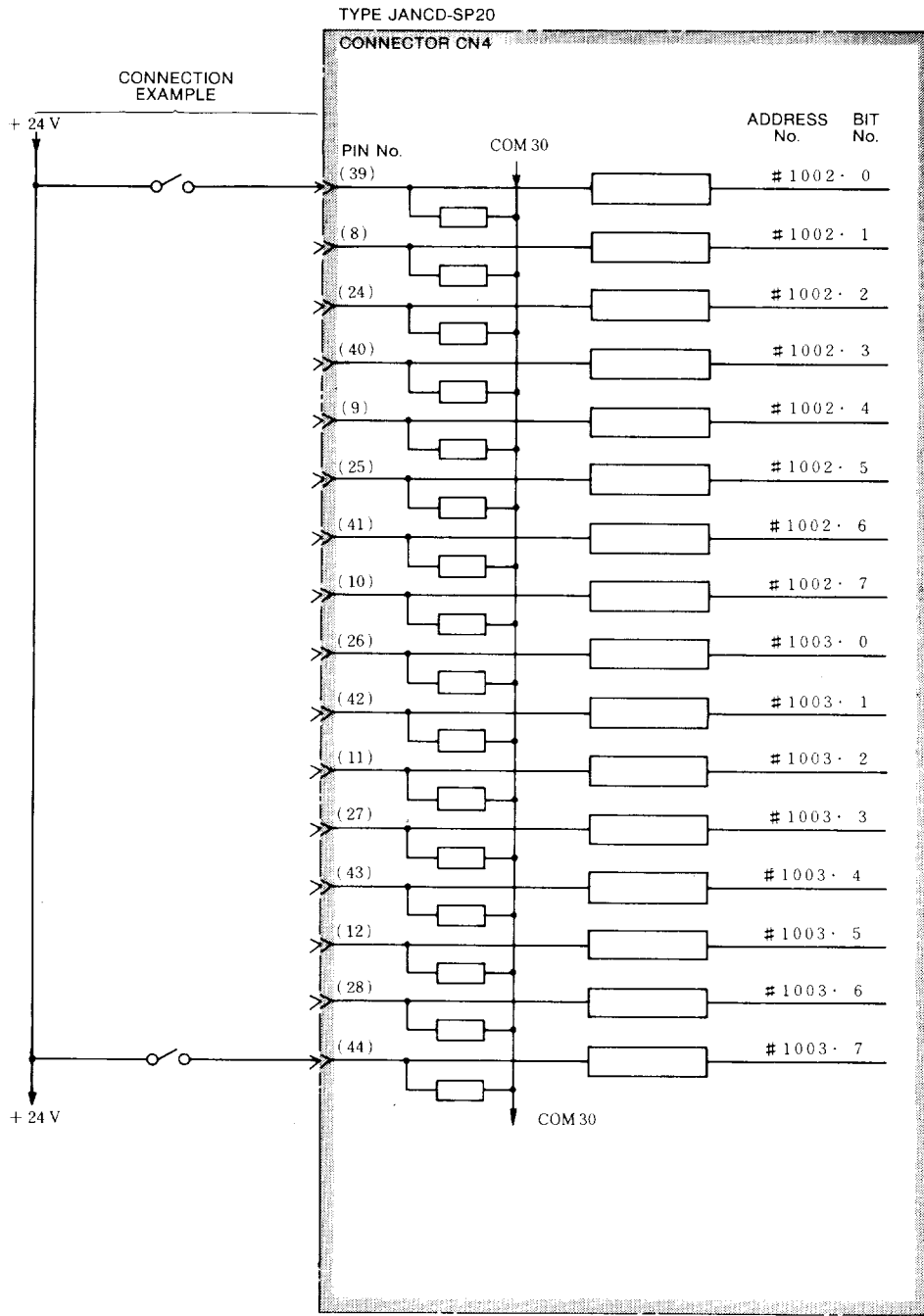

Note:

1. This connection example shows +24 V common. 0 V common is also available. Refer to par. 16.2.2, I/O Board Type JANCD-SP20 for connection details.
2. The addresses are those for module No. 1. (#1002.0 to #1003.7). The address layouts for modules Nos. 2 to 4 are the same as shown above starting with newer addresses. Refer to Appendix B (3), Address Classification for details.

Fig. 16.21 Connection of Address and Bit Nos. #1002.0 to #1003.7 on SP 20 Board

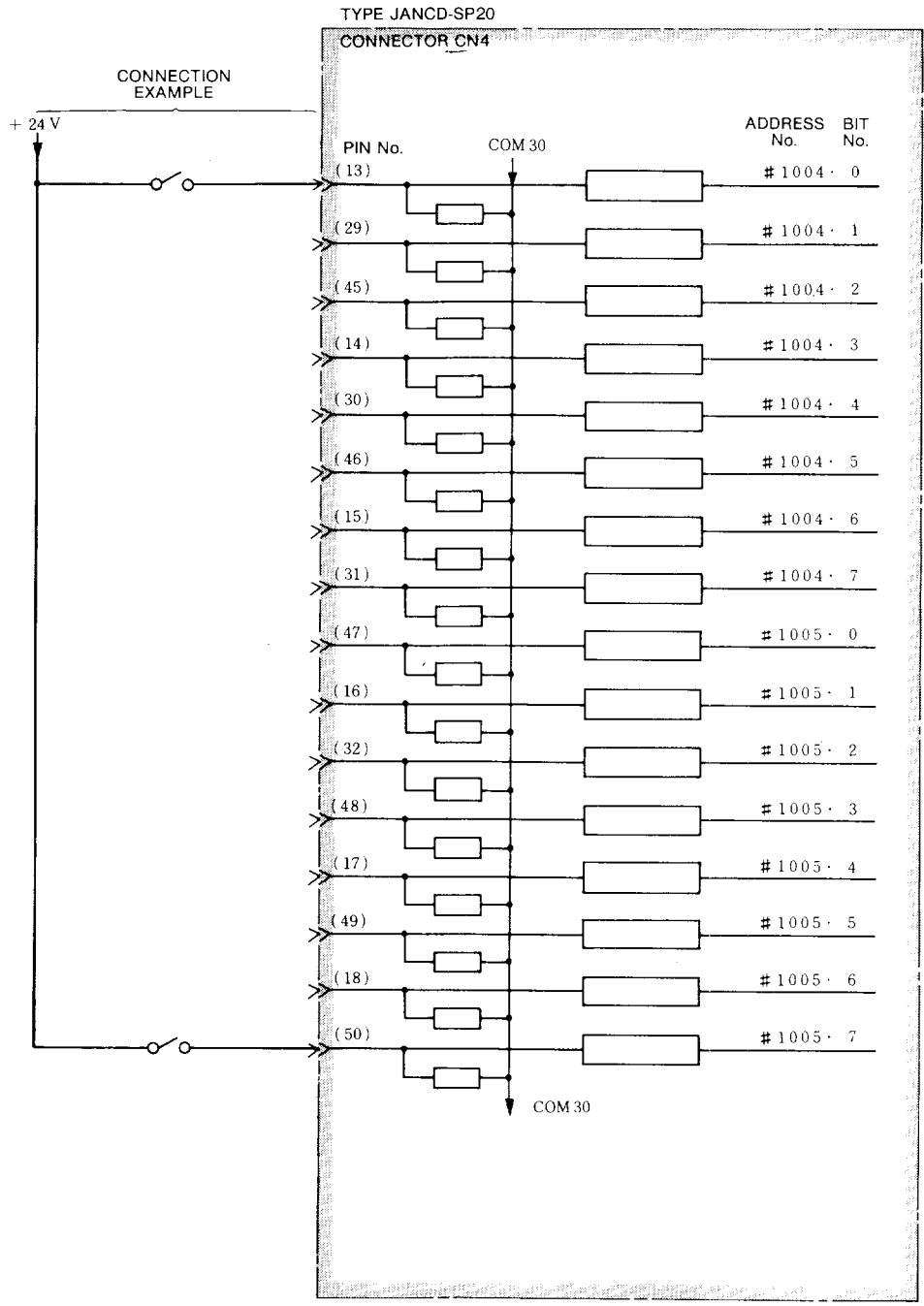

Note:

1. This connection example shows +24 V common.
0 V common is also available. Refer to par. 16.2.2, I/O Board Type JANCD-SP20 for connection details.
2. The addresses are those for module No. 1. (#1004.0 to #1005.7). The address layouts for modules Nos. 2 to 4 are the same as shown above starting with newer addresses. Refer to Appendix B(3), Address Classification for details.

Fig. 16.22 Connection of Address and Bit Nos. #1004.0 to #1005.7 on SP 20 Board

16.3.2 SP 20 BOARDS (Cont'd)

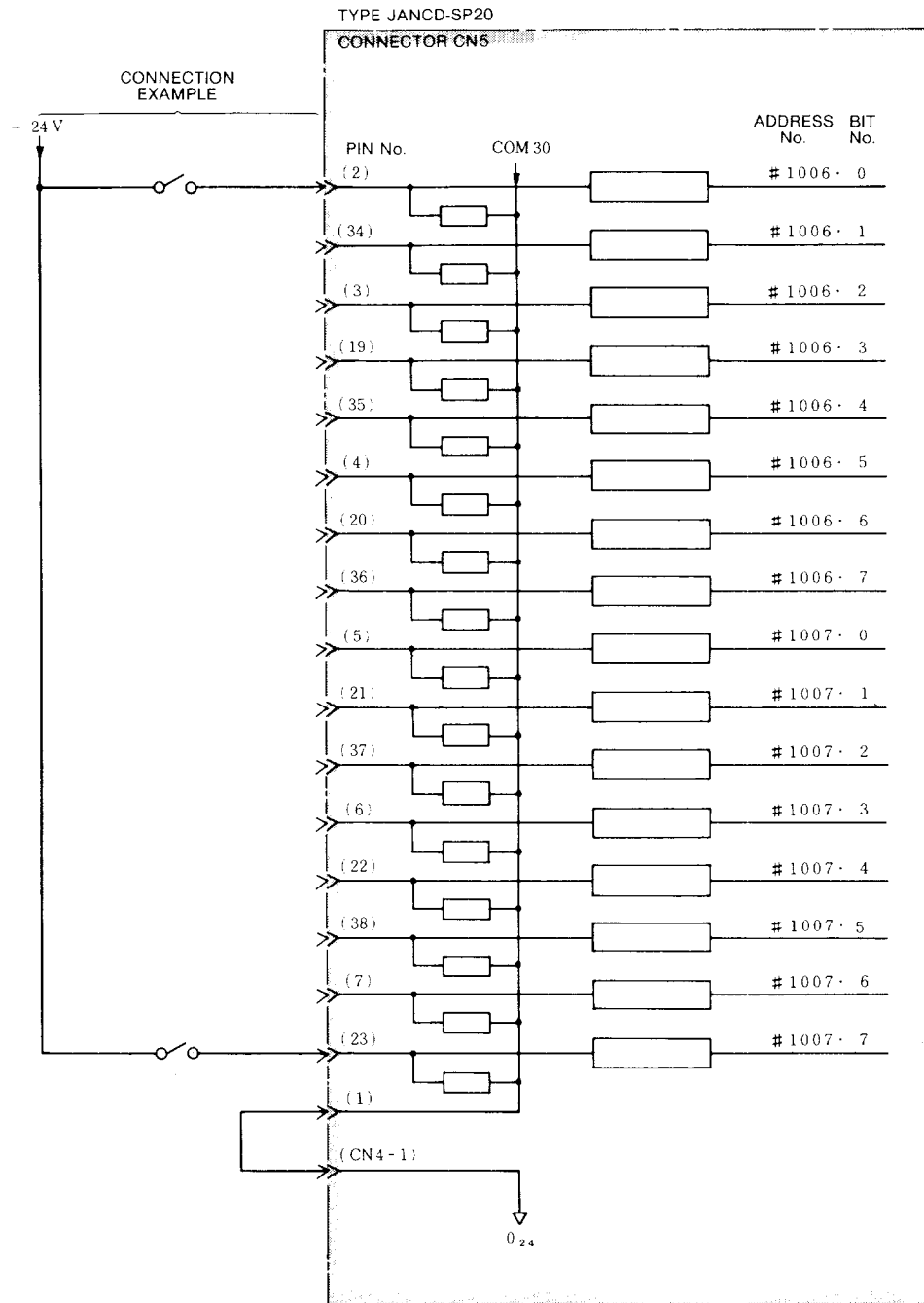

Note:

1. This connection example shows +24 V common. 0 V common is also available. Refer to par. 16.2.2, I/O Board Type JANCD-SP20 for connection details.
2. The addresses are those for module No. 1. (#1006.0 to #1007.7). The address layouts for modules Nos. 2 to 4 are the same as shown above starting with newer addresses. Refer to Appendix B(3), Address Classification for details.

Fig. 16.23 Connection of Address and Bit Nos.
#1006.0 to #1007.7 on SP 20 Board

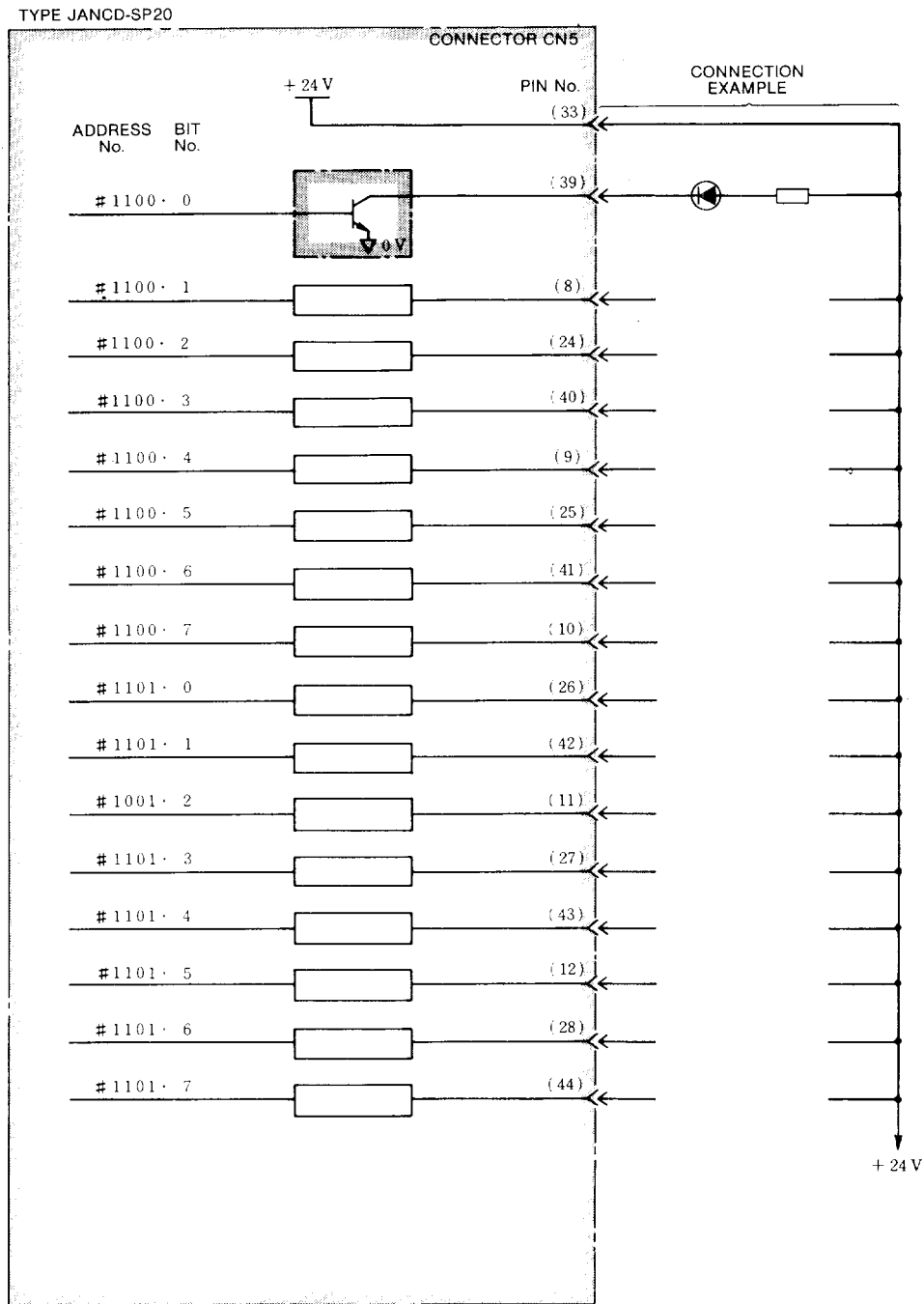

Note:

1. This connection example shows +24 V common. 0 V common is also available. Refer to par. 16.2.2, I/O Board Type JANCD-SP20 for connection details.
2. The addresses are those for module No. 1. (#1100.0 to #1101.7). The address layouts for modules Nos. 2 to 4 are the same as shown above starting with newer addresses. Refer to Appendix B(3), Address Classification for details.

Fig. 16.24 Connection of Address and Bit Nos. #1100.0 to #1101.7 on SP 20 Board

16.3.2 SP 20 BOARDS (Cont'd)

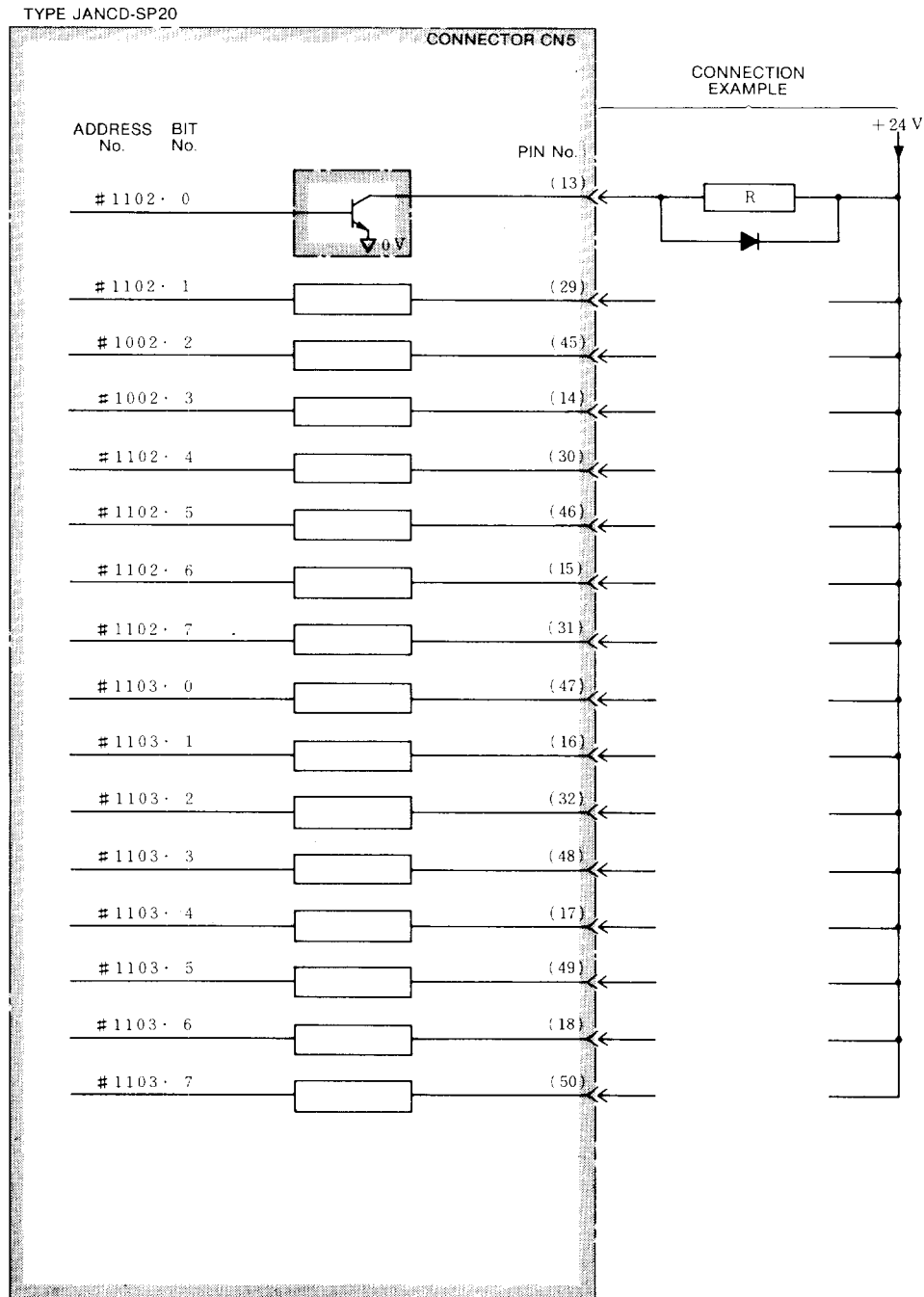

Note:

1. This connection example shows +24 V common. 0 V common is also available. Refer to par. 16.2.2, I/O Board Type JANCD-SP20 for connection details.
2. The addresses are those for module No. 1. (#1102.0 to #1103.7). The address layouts for modules Nos. 2 to 4 are the same as shown above starting with newer addresses. Refer to Appendix B(3), Address Classification for details.

Fig. 16.25 Connection of Address and Bit Nos. #1102.0 to #1103.7 on SP 20 Board

17. CABLES

17.1 LIST OF CABLES

The interface cables are furnished with or without connectors. Those cables shown in Table 17.1 are available.

If the machine manufacturer is supplying the cables, prepare equivalent cables based on the cable specifications.

• Connector Cable Type

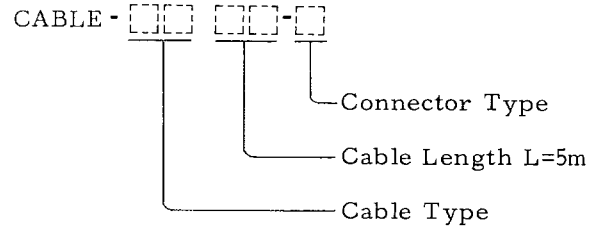

Table 17.1 List of Cables

Cable No.	Cable Type	Configuration	Remarks	Cable No.	Cable Type	Configuration	Remarks
(C1) (C2) (C3)	CABLE-MA[]-1	<p>Type KQVV-SB</p>	<ul style="list-style-type: none"> Servo drive unit Max cable length: 15 m 	(C22)	CABLE-AA[]-1	<p>Type KQVV-SB, DE8400093 0.2 mm² × 10 pairs</p>	<ul style="list-style-type: none"> CRT operator's panel signal Max cable length: 20 mm
(C4)	CABLE-JA[]-1	<p>Type KQVV-SB, DE8400093 0.2 mm² × 10 pairs</p>	<ul style="list-style-type: none"> Spindle optical encoder Max cable length: 15 m 	(C51) (C53) (C54) (C55) (C104) (C105)	*	Connector C51, CN53, CN54, CN55: Types MRP-50F01, MR-50LW Cable: Type KQVV, DE8400095 0.2 mm ² × 50 cores	I/O
(C5)	*	Connector CN4: Type MRP-20M01, MR-20LW Cable: Type KQVV, DE6428673 0.2 mm ² × 20 cores	<ul style="list-style-type: none"> For input sequence 	(C52)	*	Connector: Types MRP-20F01, MR-20LW Cable: Type KQVV, DE8408673 0.2 mm ² × 20 cores	I/O
(C6)	*	Connector CN6: Types MRP-20M01, MR20LW 1R0, 2R0: Type DB-25S Cable: Type KQVV, DE6428673 0.2 mm ² × 20 cores	RS-232C interface	(C101)	CABLE-JF[]-2	Type MRP-20M01, M4 AMPLIFIER TERMINAL Type MR-20LW <p>Type KQVV-SB, DE8400093 0.2 mm² × 10 pairs</p>	Manual pulse generator
(C7)	-	-	Not used.				
(C8)	*	Connector CN8: Types MRP-20F01, MR-20LW Cable: Type KQVV, DE6428673 0.2 mm ² × 20 cores	I/O		CABLE-CC[]-1	<p>Type KQVV-SB, DE8400093</p>	Optical encoder forward connector
(C11)	CABLE-EA[]-1	<p>Type VCT, DE8402398 0.2 mm² × 5 cores</p>	<ul style="list-style-type: none"> Power supply for CRT operator's panel Max cable length: 15 m 	(C212) (C232)	CABLE-CD[]-1	<p>Type KQVV-SB, DE8400093</p>	Optical encoder reverse connection
(C12)	-	-	Not used.	(C212) (C232)			
(C13)	*	Connector CN13: Type 172025-1 Cable: Type KQVV-SB, DE8402398 2 mm ² × 5 cores	AC power supply				

*Connector and cable are separately provided.

17.2 LIST OF CONNECTORS

17.2.1 CPU MODULE

Table 17.2 Connectors of CPU Module

CPU Module Type	Connector No.	Connector Type for Board Side	Connector Type for Cable Side
JANCD-MB20	CN1	MR-50RMD2	MRP-50F01
	CN2	MR-50RMD2	MRP-50F01
	CN3	MR-50RMD2	MRP-50F01
	CN4	MR-20RMD2	MRP-20F01
	CN5	MR-20RMD2	MRP-20F01
	CN6	MR-20RFD2	MRP-20M01
	CN7	MR-20RFD2	MRP-20M01
	CN8	MR-20RMD2	MRP-20F01
JANCD-PC20	CN21	MR-20RMA	MRP-20F01
	CN22	MR-20RMA	MRP-20F01
JANCD-IO20	CN51	MR-50RMA	MRP-50F01
	CN52	MR-20RMA	MRP-20F01
	CN53	MR-50RMD2	MRP-50F01
	CN54	MR-50RMD2	MRP-50F01
	CN55	MR-50RMD2	MRP-50F01
CPS-10N	CN11	172040-1 (5 pairs)	172026-1
	CN12	172040-1 (5 pairs)	172026-1
	CN13	172039-1 (7 pairs)	172025-1

Note: Connectors for the cable side are not attached to the cables. The machine manufacturer must supply equivalent connectors.

17.2.2 CPT OPERATOR'S PANEL

Table 17.3 Connectors of CRT Operator's Panel

CRT Panel Type	Connector No.	Connector Type for Board Side	Connector Type for Cable Side
JANCD-SP20	CNA	FRC2-C40S11-0S	Connected
	CNB	MR-20RMD2	MRP-20F01
	CN1	MR-20RFD2	MRP-20M01
	CN2	MR-20RMD2	MRP-20F01
	CN3	172037-1(5 pairs)	172026-1(5 pairs)
	CN4	MR-50RMD2	MRP-50F01
	CN5	MR-50RMD2	MRP-50F01

17.2.3 FEED DRIVE UNIT

Table 17.4 Connectors of Feed Drive Unit

Feed Drive Unit Type	Connector No.	Connector Type for Board Side	Connector Type for Cable Side
CACR-SR□□SB	CN1	MR-50RMF	MR-50F
	CN2	MR-20RMA	MR-20F

Note: Connector layout of SP20 board is as follows:

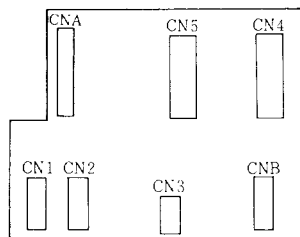

17.3 SPECIFICATIONS OF CABLE

(1) Cable DWG. No. DE8400093(Type KQVV-SB, 0.2mm²x 10 pairs)

Table 17.5 Construction

No. of Pairs		10
Conductor	Material	Tinned annealed copper stranded wire
	Nominal Sectional Area mm ²	0.2
	No. of Conductors per mm	16/0.12
	Dimensions mm	0.55
Insulation	Material	Cross-linked vinyl
	Thickness mm	0.3
Winding		Paper tape lap winding
Shield		Tinned annealed copper stranded wire
Sheath	Material and Color	Vinyl, black
	Thickness mm	1.2
Dimensions mm		10.0
Approx Weight kg/km		130

Table 17.6 Characteristics

Max Conduction Resistance (20°C)	Ω/km	113
Min Insulation Resistance (20°C)	MΩ·km	50
Withstand Voltage	VAC/min	1000
Continuous Operation Temperature Range	°C	-30 to +60

• Layout of 10 Pairs

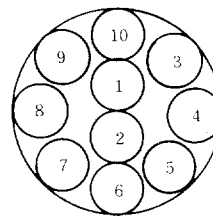

Pair No.	Colors
1	Blue/White
2	Yellow/White
3	Green/White
4	Red/White
5	Purple/White
6	Blue/Brown
7	Yellow/Brown
8	Green/Brown
9	Red/Brown
10	Purple/Brown

Note: Drain wires of 0.2 mm² are provided inside tinned annealed-copper stranded wire.

(2) Cable DWG. No. DE 8400095 (Type KQVV-SB, 0.2mm²x 50 cores)

Table 17.7 Construction

No. of Cable Cores		50
Conductor	Material	Tinned annealed-copper stranded wire
	Nominal Sectional Area mm ²	0.2
	No. of Conductors per mm	16/0.12
	Dimensions mm	0.55
Insulation	Material	Cross-linked vinyl
	Thickness mm	0.3
Winding		Paper tape lap winding
Sheath	Material and Color	Soft vinyl, black
	Thickness mm	1.2
Finished Cable Diameter mm		Approx 13
Approx Weight kg/cm		230

Table 17.8 Characteristics

Max Conduction Resistance (20°C)	Ω/km	113
Min Insulation Resistance (20°C)	MΩ·km	50
Withstand Voltage	VAC/min	1000
Continuous Operation Temperature Range	°C	- 30 to + 60

• Details of Cable DWG. No. DE 8400095

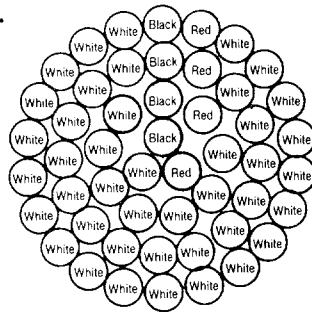

(3) Cable DWG. No. DE 6428673 (Type KQVV, 0.2mm²x 20 cores)

Table 17.9 Construction

No. of Cable Cores		20
Conductor	Material	Tinned annealed-copper stranded wire
	Nominal Sectional Area mm ²	0.2
	No. of Conductors per mm	16/0.12
	Dimensions mm	0.55
Insulation	Material	Cross-linked vinyl
	Thickness mm	0.3
Winding		Paper tape lap winding
Sheath	Material and Color	Soft vinyl, black
	Thickness mm	1.2
Finished Cable Diameter mm		8.0
Approx Weight kg/km		90

Table 17.10 Characteristics

Max Conduction Resistance (20°C)	Ω/km	113
Min Insulation Resistance (20°C)	MΩ·km	50
Withstand Voltage	VAC/min	1000
Continuous Operation Temperature Range	°C	- 30 to + 60

• Details of Cable DWG. No. DE 6428673

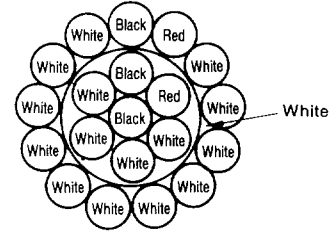

(4) Cable DWG. No. DE 8402398 (Type VCT, 2mm²x 5 cores)

Table 17.11 Construction

No. of Pairs		5
Conductor	Material	Tinned annealed copper stranded wire
	Nominal Sectional Area mm ²	2.0
	No. of Conductors per mm	37/0.26
	Dimensions mm	1.8
Insulation	Material	Insulation vinyl
	Thickness mm	0.8
Stranding		Right twisted (outer diameter: approx 9.2 mm)
Sheath	Material and Color	Vinyl, black
	Thickness mm	Approx 1.9
Dimensions mm		13.0

Table 17.12 Characteristics

Max Conduction Resistance (20°C)	Ω/km	10.2
Min Insulation Resistance (20°C)	MΩ·km	50 or more
Withstand Voltage	VAC/min	3000

• Details of Cable DWG. No, DE8402398

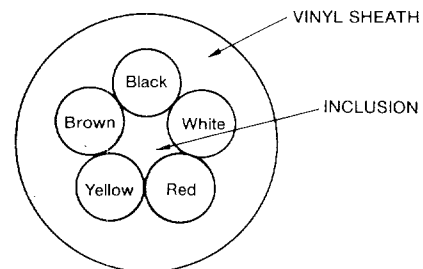

18. STANDARD I/O SIGNALS

18.1 LIST OF NC STANDARD I/O SIGNALS

Input Signals

	D ₇	D ₆	D ₅	D ₄	D ₃	D ₂	D ₁	D ₀
#1300	EDT EDIT	MEM MEMORY	MDI MDI	T TAPE		H/S HANDLE/ STEP	J MANUAL JOG	RPD MANUAL RAPID
#1301	MP1	ROV2	ROV1	FV16	FV8	FV4	FV2	FV1
	RAPID SPEED OVERRIDE			FEEDRATE OVERRIDE/MANUAL JOG SPEED				
#1302	HZ	HX	-Z	+Z	-X	+X	MP4	MP2
	MANUAL PG AXIS SELECT		MANUAL TRAVERSE AXIS DIRECTION SELECT			MANUAL PG MULTIPLY SELECT		
#1303	INHEDT INHIBIT EDIT	AFL M. S. T LOCK	ABS MANUAL ABS.	DRN DRY RUN	BDT BLOCK DELETE	DLK DISPLAY LOCK	MLK MACHINE LOCK	SBK SINGLE BLOCK
#1304	ZRN RETURN TO REFER- ENCE	CDZ THREAD CUT UP	SWZ ERROR DETECT ON	RWDH HIGH-SPEED REWIND	SRN SET UP POINT RETURN	PST POSITION SET	*SP FEED HOLD	ST CYCLE START
#1305	ERR1	ERR0	STLK	RWD	EOP	ERS	FIN	MRD
	EXTERNAL ERROR INPUT		INTER- LOCK	REWIND	END OF PROGRAM	EXTERNAL RESET	MST FIN	MACHINE READY
#1306	SAGR SPINDLE SPEED AGREE- MENT		*DCZ	*DCX	*-LZ	*+LZ	*-LX	*+LX
		DECREASE INPUT FOR REFERENCE POINT			OVERTRAVEL INPUT			
#1307	GRS DURING GEAR SHIFT	GSC SPINDLE SPEED CONSTANT	SSTP S- COMMAND "0"	SINV S- COMMAND INVERT	GR4	GR3	GR2	GR1
					SPINDLE GEAR RANGE SELECT			
#1308	EOUT NC PROGRAM PUNCH OUT	EVER NC PROGRAM VERIFY	EIN NC PROGRAM INPUT	DRSZ	DRSX			EXTC TIME COUNT
			DISPLAY RESET					
#1309	BDT9	BDT8	BDT7	BDT6	BDT5	BDT4	BDT3	BDT2
	OPTIONAL BLOCK DELETE							

	D ₇	D ₆	D ₅	D ₄	D ₃	D ₂	D ₁	D ₀
#1310	WN 16	WN 8	WN 4	WN 2	WN 1	SPC	SPB	SPA
	EXTERNAL WORK NUMBER SEARCH					SPINDLE OVERRIDE		
#1311				CPFN	HOFS	MIX	PRST	OVC
				CUTTING INTERRUPT POINT RETURN	AUTO MODE HANDLE OFFSET	X AXIS MIRROR IMAGE	PROGRAM RESTART	OVERRIDE CANCEL
#1312				COV16	COV8	COV4	COV2	COV1
	MULTIPLE REPETITIVE CYCLES							
#1313								
#1314								
#1315								
#1316	SID 8	SID 7	SID 6	SID 5	SID 4	SID 3	SID 2	SID 1
	SPINDLE INDEX POSITION SET							
#1317	TP 8	TP 4	TP 2	TP 1	SID 12	SID 11	SID 10	SID 9
	TOOL NO. SET FOR STORED STROKE LIMIT							
#1318	TLTM	TLCNT	TLSKP	TLRST	SIDXI	SIDXING	TPS	SIDX
	TIMER COUNT		TOOL SKIP	TOOL RESET	SPINDLE INDEX RESTART	SPINDLE INDEX POSITION INCRE- MENTAL DESIGNA- TION	TOOL NO CHANGE FOR S. S. LIMIT	SPINDLE INDEXING
	SIGNAL FOR TOOL LIFE CONTROL							
#1319	ROV 4	SPE	SPD	TLA 16	TLA 8	TLA 4	TLA 2	TLA 1
	RAPID OVERRIDE	SPINDLE OVERRIDE		CHANGE TOOL NO. (TOOL LIFE CONTROL)				

18.1 LIST OF NC STANDARD I/O SIGNALS (Cont'd)

Input Signals

	D ₇	D ₆	D ₅	D ₄	D ₃	D ₂	D ₁	D ₀
#1320								
#1321								
#1322	SONPB SERVO POWER ON							
#1323	(SDI 7)	(SDI 6)	(SDI 5)	(SDI 4)	(SDI 3)	(SDI 2)	(SDI 1)	(SDI 0)
	EXTERNAL INPUT OF S-COMMAND (S 4 DIGIT) NO. 1							
#1324	(SDI 15)	(SDI 14)	(SDI 13)	(SDI 12)	(SDI 11)	(SDI 10)	(SDI 9)	(SDI 8)
	EXTERNAL INPUT FOR S-COMMAND (S 4 DIGIT) NO. 2							
#1325	UI 7	UI 6	UI 5	UI 4	UI 3	UI 2	UI 1	UI 0
	INPUT FOR "MACRO PROGRAM" NO. 1							
#1326	UI 15	UI 14	UI 13	UI 12	UI 11	UI 10	UI 9	UI 8
	INPUT FOR "MACRO PROGRAM" NO. 2							
#1327	ED 7	ED 6	ED 5	ED 4	ED 3	ED 2	ED 1	ED 0
	EXTERNAL DATA INPUT NO. 1							
#1328	ED 15	ED 14	ED 13	ED 12	ED 11	ED 10	ED 9	ED 8
	EXTERNAL DATA INPUT NO. 2							
#1329	EDCL	EDS 2	EDS 1	EDS 0	EDSD	EDSC	EDSB	EDSA
	CONTROL SIGNAL FOR EXTERNAL DATA INPUT							

Output Signals

	D ₇	D ₆	D ₅	D ₄	D ₃	D ₂	D ₁	D ₀
#1200	M28	M24	M22	M21	M18	M14	M12	M11
	M FUNCTION BCD OUTPUT							
#1201	M30R	M02R	M01R	M00R	M38	M34	M32	M31
	M30 DECODE OUTPUT	M02 DECODE OUTPUT	M01 DECODE OUTPUT	M00 DECODE OUTPUT				
#1202	TF	SF	MF	SINVA	IER	*ESPS	RST	ALM
	T-FUNC- TION SAMPL- ING OUTPUT	S-FUNC- TION SAMPL- ING OUTPUT	M-FUNC- TION SAMPL- ING OUTPUT	S4 DIGIT OUT INVERT STATUS	INPUT ERROR OUTPUT	EMERGENCY STOP OUTPUT	RESET OUT- PUT	ALARM OUTPUT
#1203		EDTS	AUTO	MAN	THC	RWDS	OP	DEN
		EDIT OPERAT- ING STATUS	AUTO MODE STATUS	MANUAL MODE STATUS	THREAD CUTTING STATUS	REWIND STATUS	FEEDING	POSITION- ING END
#1204	S28	S24	S22	S21	S18	S14	S12	S11
	S-FUNCTION BCD OUTPUT							
#1205	T28	T24	T22	T21	T18	T14	T12	T11
	T-FUNCTION BCD OUTPUT							
#1206	2 ZPZ	2 ZPX	ZPZ	ZPX		G96S	SPL	STL
	Z AXIS NO. 2 REFERENCE POSITION	X AXIS	Z AXIS REFERENCE POSITION	X AXIS		CONSTANT SURFACE SPEED CONTROL	FEED HOLD LAMP	CYCLE START LAMP
#1207								
#1216	R08 (SDO7)	R07 (SDO6)	R06 (SDO5)	R05 (SDO4)	R04 (SDO3)	R03 (SDO2)	R02 (SDO1)	R01 (SDO0)
	EXTERNAL OUTPUT FOR S-COMMAND (S4 DIGIT) NO. 1							
#1217	(SDO15)	(SDO14)	(SDO13)	(SDO12)	R012 (SDO11)	R011 (SDO10)	R010 (SDO9)	R09 (SDO8)
	EXTERNAL OUTPUT FOR S-COMMAND (S4 DIGIT) NO. 2							
#1218								

18.1 LIST OF NC STANDARD I/O SIGNALS (Cont'd)

Output Signals

	D ₇	D ₆	D ₅	D ₄	D ₃	D ₂	D ₁	D ₀
#1219	ESEND EXTERNAL DATA SEARCH COMPLE- TION	EREND EXTERNAL DATA INPUT COMPLE- TION			TLCH TOOL CHANGE COMMAND (TOOL LIFE CONTROL)	SID XO SPINDLE INDEX EXECUT- ING	TRSA S. 5. LIMIT AREA CHANGE END	SIDXA SPINDLE INDEX END
#1220	UO 7	UO 6	UO 5	UO 4	UO 3	UO 2	UO 1	UO 0
OUTPUT FOR "MACRO PROGRAM" NO. 1								
#1221	UO 15	UO 14	UO 13	UO 12	UO 11	UO 10	UO 9	UO 8
OUTPUT FOR "MACRO PROGRAM" NO. 2								
#1222								
#1223								

Monitor Signals

#1280	SSW3	SSW2	SSW1	SSW0				SKIP
SYSTEM NUMBER SWITCH								SKIP INPUT
#1281	0	*OFFPB POWER OFF PB.		ONPB POWER ON PB.	*OLD OVER- LOAD	SVAM SERVO ALARM	*ESP EMER- GENCY STOP	*OHT OVER- HEAT
#1282	1HP 7	1HP 6	1HP 5	1HP 4	1HP 3	1HP 2	1HP 1	1HP 0
NO. 1 MANUAL PULSE GENERATOR MONITOR								
#1283					SET3	SET2	SET1	SET0
#6219 MONITOR								
#1284	SVMX	SVMX						
SERVO POWER ON (= "NRD")								
#1285	0	0	0	0	0	0	0	1
CONSTANT "1"								

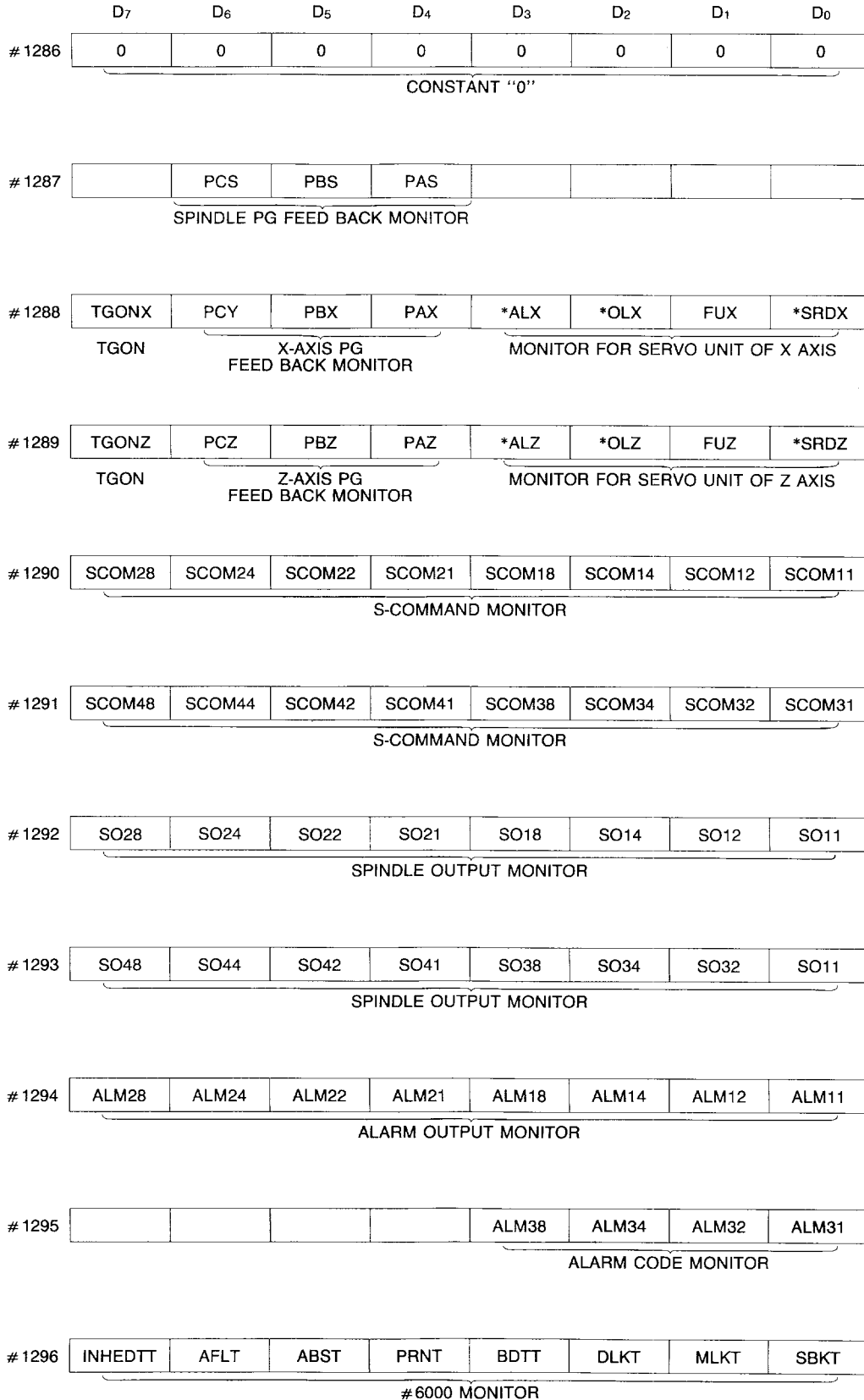

18.2 DETAILS OF SIGNALS

18.2.1 INPUT SIGNALS FOR CYCLE START (ST), STOP (*SP) OUTPUT SIGNALS DURING CYCLE START (STL) AND FEEDHOLD (SPL)

(1) With the control in any of the TAPE, MEMORY, and MDI modes, when the input contact ST is closed, the control starts automatic operation control to execute the part program, and at the same time, turn on the STL output signal for cycle start. However, an ST input is neglected under the following condition.

- While the control is in an alarm state. (While an alarm output or an input error output is on.)
- While the feedhold *SP input contact is open.
- While the external reset ERS input contact is closed.
- While the RESET button on the MDI & CRT panel is being pushed.
- While the system No. switch is in any state except for 0 and 4.

(2) When the following state is entered after cycle start, the control completes operation control, and turns off the STL output.

- When a part program has been executed by manual data input in the MDI mode.
- When one block of a part program has been executed with the single block (SBK) input contact closed.
- When the program end (EOP) input contact has been closed by an M command of a part program.

(3) When the feedhold input contact "*SP" is opened during automatic operation, the automatically controlled motions, etc. are interrupted, and, at the same time the cycle start output STL is turned off and the feedhold output SPL is turned on. While a block of thread cutting instruction is being executed, the feedhold input is neglected, unless the control is equipped with Thread Interruption function.

(4) When the feedhold input contact *SP is closed, and cycle start input contact ST is closed, temporary stop SPL is turned off, and automatic operation is restarted. The cycle start output STL is turned on also.

Timing chart for input of cycle start (ST), feedhold (*SP), and cycle start (STL) and temporary stop (SPL) is shown in Fig. 18.1.

*Asterisked signals activate at LOW.
(Normally closed contacts)

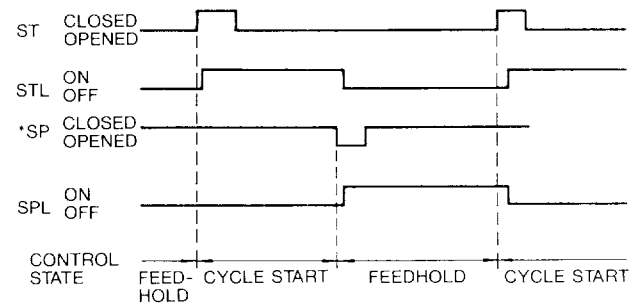

Fig. 18.1

Note:

1. Be sure to keep the cycle start (ST) and feedhold (*SP) input contacts closed or open at least for 100 ms. If the duration is shorter than this, the input may sometimes be neglected.
2. The operation of the cycle start (ST) input contact is reversed by parameter STUD(#6007D6). When the parameter is set to 1, the closing of the contact will start the operation of the control.
3. When the feedhold (*SP) input contact is opened, with the control waiting for the completion of the M, S, T, instruction (waiting for FIN input), feedhold (SPL) output is turned on, but when the M, S, T instruction completion (FIN) input contact is opened, the feedhold (SPL) output is turned off, and the control enters feedhold state.

18.2.2 INPUT AND OUTPUT FOR CONTROL OPERATION MODES (JOG, H/S, T, MDI, MEM, EDT, AUT, MAN)

(1) OPERATION MODE INPUT

The following six operation modes of the control are selected by the respective input contacts.

JOG: Manual jog mode	}	Manual operation
H/S: Manual handle/manual step feed mode		
T: Tape operation mode	}	Automatic operation mode
MDI: Manual data input operation mode		
MEM: Memory operation mode		
EDT: Program editing mode		

When any of the input contacts is closed, the corresponding operation modes is tuned on.

JOG: manual jog mode input

When the JOG input contact is closed, and other mode input contacts are opened, the control enters the manual jog mode, and the machine is jogged in the respective directions in response to the input of +X, -X, +Z and -Z signals.

H/S: Manual handle/manual step feed mode input
 When the H/S input contact is closed, and other mode input contacts are opened, the control enters the manual handle mode (when the control is provided with an optional manual pulse generator) or the manual step feed mode, and the machine will be manually fed by the manual pulse generator or fed in steps.

T: Tape operation mode

When the T input contact is closed and other mode input contacts are opened, the control enters the tape operation mode, and the machine will be controlled by the tape commands read by the tape reader.

MDI: Manual data input operation mode input

When the MDI input contact is closed, and other mode input contacts are opened, the control enters the manual data input mode, and part programs will be written or the machine will be operated through MDI.

MEM: Memory operation mode input

When the MEM input contact is closed, and other mode input contacts are opened, the control enters the memory operation mode, and the machine will be controlled by part programs stored in the memory.

EDT: Program edit mode

When the EDT input contact is closed and other operation mode input contacts are open, the control enters the program edit mode, and it can store part programs into the memory, correct and change them.

(2) OPERATION MODE OUTPUT

The control outputs the following signals to inform the current operation mode.

AUT: Automatic operation mode output

This output signal is turned on when the control is in the T (tape operation), MEM (memory operation), or MDI (manual data input operation) mode.

MAN: Manual operation mode output

This output signal is turned on when the control is in the H/S (manual handle/manual step operation mode) or JOG (manual jog mode).

EDTS: Editing output

This output signal is turned on when the control is in the EDT (program editing) mode, and also performing and editing operation (part program reading, collation, punching, and stored program changing and other processing).

Timing chart for input and output for control operation modes are shown in Fig. 18.2.

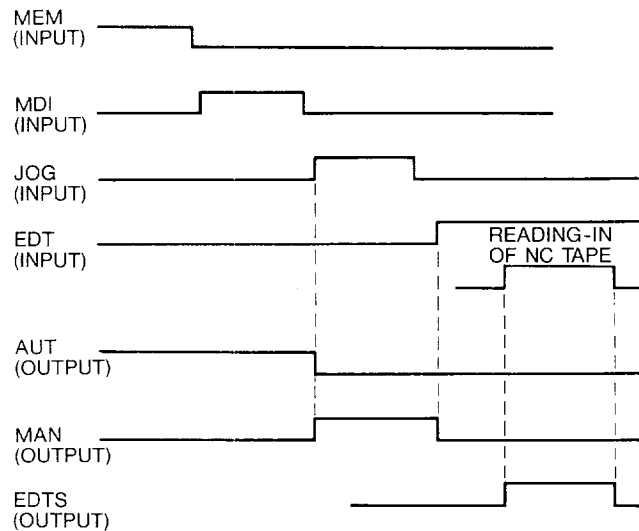

Fig. 18.2

Note:

1. When any operation-mode-input except manual operation mode is given during NC program operation in the memory operation mode, the control stops the execution of the part program after the execution of the current block. The same applies to the part program operation in the tape and MDI modes.
2. When a manual-operation-mode-input contact is closed during the execution of a part program in the memory operation mode, the following changes take place.

• Motion command

The current motion stops after deceleration, and the program is interrupted. The remaining program can be restarted when the automatic operation mode is turned on again and the cycle start (ST) input contact is closed.

• M, S, T command

The sampling outputs (MF, SF, TF) and the M code outputs are turned off, and the M, S, T command is regarded to have been executed completely.

Even when the control is returned to the automatic operation mode, the interrupted M, S, T command is not resumed.

The above applies to S2-digit commands. S4-digit commands do not have sampling output.

3. When an automatic operation mode or program editing mode input contact is closed during motion in the manual operation mode, the motion decelerates and stops.
4. When any of these operation mode input contacts is closed, that mode becomes effective. Under other input states, the previous operation mode remains effective. When no operation-mode-input-contact is closed after the energization, or when two or more operation mode input contacts are closed, the control enters the manual jog mode.

18.2.2 INPUT AND OUTPUT FOR CONTROL OPERATION MODES (JOG, H/S, T, MDI, MEM, EDT, AUT, MAN) (Cont'd)

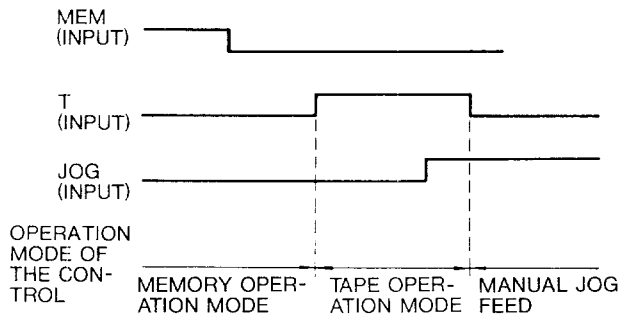

Fig. 18.3

5. When a manual operation mode input contact is closed during the thread-cutting process in a part program, the automatic operation mode is retained while the thread is being cut.

18.2.3 MANUAL RAPID TRAVERSE SELECTION (RPD) INPUT

When the RPD input contact is closed while the control is in the manual jog mode, manual feeding in the +X, -X, +Z and -Z directions is performed in the rapid traverse rate.

After power supply is input, JOG feed rate can be used as RPD feed rate by parameter (#6009 D3=1) until reference point return for each axis has been executed completely.

18.2.4 MANUAL HANDLE FEED AXIS SELECTION (HX, HZ) INPUT, AND AUTOMATIC MODE HANDLE OFFSET (HOF S) INPUT

(1) MANUAL HANDLE FEED AXIS SELECTION (HX, HZ) INPUT

This is the input signal for selecting the motion axis for the motion by the manual pulse generator, with a control provided with a manual pulse generator. When the HX input contact is closed and the HZ input contact is open, the motion takes place along the X-axis. When the HZ input contact is closed and the HX input contact is open, the motion takes place along the Z-axis.

Note:

1. When both the HX and HZ input contacts are closed or open, motion cannot be obtained by the manual pulse generator.
2. When the control is provided with a pulse generator for simultaneous 2-axis control, and when a manual step feed is intended, these input contacts are not used.

(2) AUTOMATIC MODE HANDLE OFFSET (HOF S) INPUT

This input is for enabling motion control with the manual handle even during the automatic operation mode (Tape mode, MDI mode, memory mode) with a control provided with a manual pulse generator.

With this input, relative displacements caused by the remounting of the workpieces during automatic operation can be compensated.

When the HOF S input contact is closed, the motion control by the manual pulse generator is effective even during the automatic operation mode. However, during the execution of a positioning command in the automatic operation mode, machine motion cannot be controlled by the manual pulse generator.

The motion axis for the manual pulse generator motion control is selected by the HX and HZ (manual handle feed axis selection) input contacts. When the control is provided with a simultaneous 2-axis manual pulse generator, the machine can be moved simultaneously along the two axes.

The travel distance per step of the manual pulse generator is determined by the MP1, MP2 and MP4 (manual handle multiplication factor setting) input.

Note:

1. In an alarm state (ALM or IER output contact is closed), needless to say, automatic mode handle offset motion is ineffective.
2. When the interrupt input (STLK) contact is closed, manual handle mode motion is possible, but automatic mode handle offset motion is not possible.
3. When executing automatic mode handle offset motion, parameter #6022, D₀ and D₁ for HOF SX (X-axis motion) and HOF SZ (Z-axis motion) must be set to 1.
4. When parameter HOF SMV (#6022 D₇) is set to 1, the automatic mode handle offset motion can be applied only to the time during the interpolation in the automatic operation modes.

18.2.5 MANUAL FEED AXIS DIRECTION SELECTION (+X, -X, +Z, -Z) INPUT

These inputs specify the motion direction when the control is in the manual jog mode or manual step feed mode.

Table 18.1 Motion Direction of Axis

+X	-X	+Z	-Z	Motion Direction of Axis
1	0	0	0	Plus direction of X-axis
0	1	0	0	Minus direction of X-axis
0	0	1	0	Plus direction of Z-axis
0	0	0	1	Minus direction of Z-axis

1: Closed, 0: Open

Under other input conditions, axis motion is impossible, and current axis motion is stopped after deceleration.

18.2.6 MANUAL HANDLE/STEP MULTIPLICATION FACTOR (MP1, MP2, MP4) INPUT

When the control is in the manual handle/manual step feed mode, the motion distance per step is determined by these input signals.

Table 18.2 Manual Handle/Step Multiplication Factor

MP1	MP2	MP4	Manual Step Feed	Manual Feed Handle
0	0	0	1 pulse/step	
1	0	0	10 pulses/step	
0	1	0	100 pulses/step	
1	1	0	1000 pulses/step	100 pulses/step
1 or 0		1	10,000 pulses/step	100 pulses/step

1: Closed, 0: Open

Note: Only when manual handle multiplication factor is 100 pulses/step, the control can be used by any multiplication. The multiplication factor should be set parameter #6223.

18.2.7 FEED OVERRIDE/MANUAL JOGGING SPEED SELECTION (FV1, FV2, FV 4, FV8, FV16) INPUT, AND FEED OVERRIDE CANCEL (OVC) INPUT

(1) These input signals are for specifying override speeds between 0 and 200% at 10% intervals on the programmed speeds. In the manual jog mode, these inputs determine the manual jog feed rates.

Table 18.3

FV1	FV2	FV4	FV8	FV16	Feedrate Override (Automatic Operation Mode)	Manual Jog Feedrate (Manual Operation Mode) Parameter Setting
0	0	0	0	0	0 %	# 6233
1	0	0	0	0	10 %	# 6234
0	1	0	0	0	20 %	# 6235
1	1	0	0	0	30 %	# 6236
0	0	1	0	0	40 %	# 6237
1	0	1	0	0	50 %	# 6238
0	1	1	0	0	60 %	# 6239
1	1	1	0	0	70 %	# 6240
0	0	0	1	0	80 %	# 6241
1	0	0	1	0	90 %	# 6242
0	1	0	1	0	100 %	# 6243
1	1	0	1	0	110 %	# 6244
0	0	1	1	0	120 %	# 6245
1	0	1	1	0	130 %	# 6246
0	1	1	1	0	140 %	# 6247
1	1	1	1	0	150 %	# 6248
0	0	0	0	1	160 %	# 6249
1	0	0	0	1	170 %	# 6250
0	1	0	0	1	180 %	# 6251
1	1	0	0	1	190 %	# 6252
0	0	1	0	1	200 %	# 6253
1	0	1	0	1	0 %	# 6254
0	1	1	0	1		# 6255
1	1	1	0	1		# 6256
0	0	0	1	1		# 6257
1	0	0	1	1		# 6258
0	1	0	1	1		# 6259
1	1	0	1	1		# 6260
0	0	1	1	1		# 6261
1	0	1	1	1		# 6262
0	1	1	1	1		# 6263
1	1	1	1	1		# 6264

1: Closed, 0: Open

Note for Table 18.3 :

- When parameter FOVAB (#6020D5) is set to 1, inputs FV1, FV2, FV4, FV8, and FV16 become effective when the contacts are open, and 0 and 1 in the table for the input state and feed override manual jog speeds are reversed.
- The manual jog feed rates can be used as the feed rates for part program by run execution in the automatic operation modes. For details, refer to 18.2.14 Dry Run (DRN) Input.
- For the thread-cutting in part program execution in the automatic operation modes, override is possible only at 100%.

(2) FEED OVERRIDE CANCEL (OVC) INPUT

This is the input for fixing the feedrate override at 100%. When the OVC input contact is closed, the feed rate in part program execution in the automatic operation modes is locked at the programmed value, irrespective of the override input conditions.

18.2.8 RAPID FEEDRATE OVERRIDE (ROV1, ROV2, ROV4) INPUT

These inputs are for overriding the rapid feed rates, i.e., the positioning speed when executing programs in the automatic operation modes, and the motion speed in the manual jog mode when the RT input contact is closed.

Table 18.4

Input State		Rapid Feedrate	
ROV1	ROV2	X-axis	Z-axis
1	1	# 6280 Setting speed	# 6281 Setting speed
0	1	# 6280 Setting speed × $\frac{1}{2}$	# 6281 Setting speed × $\frac{1}{2}$
1	0	# 6280 Setting speed × $\frac{1}{4}$	# 6281 Setting speed × $\frac{1}{4}$
0	0	F ₀ (# 6231 Setting speed)	

1: Closed, 0: Open

Rapid feedrate override is changed from 4 steps to 6 steps by parameter #6018·D2 = 1.

Table 18.5

Input State			Rapid Feedrate	
ROV1	ROV2	ROV4	X-axis	Z-axis
1	0	1	100 %	100 %
0	0	1	50 %	50 %
1	1	0	25 %	25 %
0	1	0	10 %	10 %
1	0	0	5 %	5 %
0	0	0	F ₀ (# 6231 Setting speed)	

1: Closed, 0: Open

18.2.9 REFERENCE POINT RETURN CONTROL I/O SIGNALS (ZNR, *DCX, *DCZ)

These are input and output signals for bringing the machine to the machine reference point upon the energization of the control.

(1) GRID METHOD

Reference point is determined by the origin pulse (1 pulse/revolution) of the position detector. After turning on the power supply, when the manual jog mode is turned on, and the manual reference point return input contact ZRN is closed, the direction of axis motion set by parameter ZRNDRX, ZRNDRZ (#6010 D0, D1) will result in the reference point return motion as shown below. (The same applies to the execution of G28 in the automatic operation modes.)

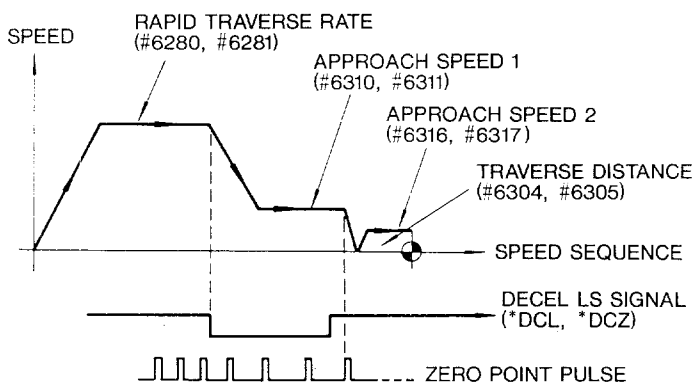

Fig. 18.4

When the machine is returned to the reference point once, the return motion, thereafter will be in the positioning motion to the determined reference point.

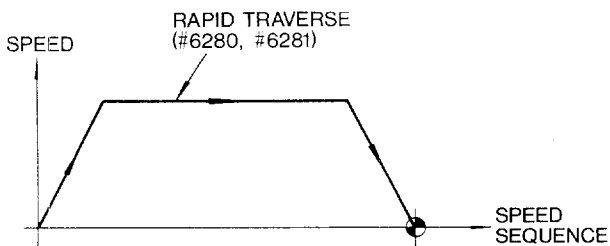

Fig. 18.5 Reference Point Return Motion after First Power ON

However, when parameters MZRNHS, AZRNHS (#6010 D4, D5) are set to 1, the same reference point return motion is obtained also for the 2nd time onward.

(2) X AND Z REFERENCE POINTS (ZPX, ZPZ) OUTPUT

While the machine is remaining at the reference point after the reference point return motion or positioning to the reference point, the ZPX and ZPZ output contacts are closed. If the actual position is not within ± 3 pulses from the reference point due to the use of metric input in the inch output system or vice versa, the ZPX and ZPZ output contacts are not closed.

(3) 2ND REFERENCE POINT (ZPX, ZPZ) OUTPUT

When the machine has been positioned to the 2nd reference point by the execution of the part program command G30 in the automatic operation mode, the ZPX, and ZPZ output relays are closed, and remain closed as long as the machine remains at this point. The 2nd reference point is defined by the distance from the reference point as set by parameters XZP2L, ZPZ2L (#6612, #6613).

18.2.10 MANUAL ABSOLUTE ON/OFF (ABS) INPUT

During the execution of part programs in the automatic operation mode, the control stores the command values in an internal command value register (command values are displayed on the 1st CRT area), and the displacement distance between the stored value and the coordinate value in the part program.

Since the control must also control the current position, it controls the current values in the absolute coordinate system (to be displayed in the 2nd CRT area. The coordinate system is defined by a coordinate system setting command.)

This input is for determining whether the current value in the absolute coordinate system is transferred to the command value register or not at the start of the execution of the respective blocks of part programs in the automatic mode.

- When ABS input relay is open: Does not transfer.
- When ABS input relay is closed: To be transferred, except when circular interpolation is used.

The motion path after a manual control intervention in the automatic operation mode is changed as follows by an ABS input.

(1) WHEN ABS INPUT RELAY IS OPEN

The motion path after an intervention by manual axial motion, is the one shifted parallel from the original path by the distance covered by the manual motion.

```
G01 Z20.000 FΔΔ;
X20.000 Z30.000 ← ①
X10.000 Z40.000
```

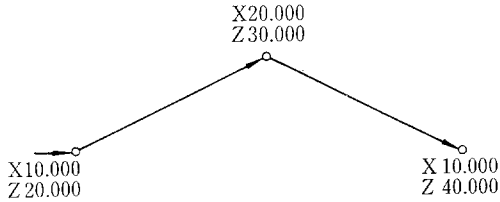

Fig. 18.6

① When the machine is manually moved during a block.

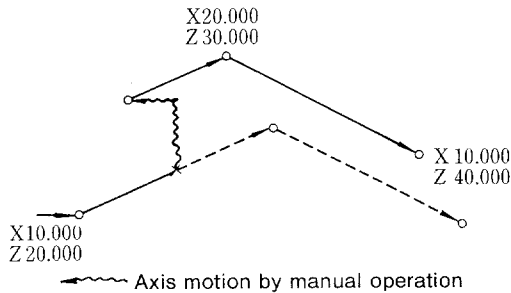

Fig. 18.7

(2) WHEN ABS INPUT RELAY IS CLOSED.

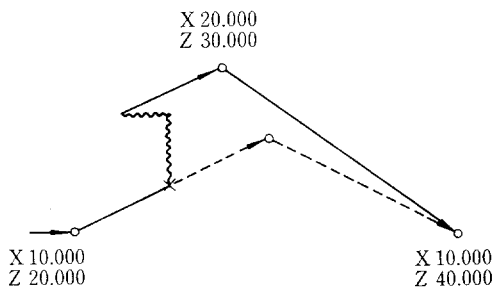

Fig. 18.8

(3) SUPPLEMENTARY DESCRIPTION

In the following cases, the control transfers current value in the absolute coordinate system (coordinate system displayed in the CRT current value 2nd area, or the one determined by coordinate system setting instructions) to the command value register unconditionally.

- RESET operation: MDI panel RESET key—on or external reset (ERS) input contact closed
- End of program: Program reset through end of program (EOP) input contact closing by M02, M30 execution
- Automatic return to reference point: Execution of G28 command

After transferring the current value in the absolute coordinate system to the command value register, manual axial movement is reflected on the automatic axial movement even when the ABS input contact is closed.

When the block ① is searched again by the RESET operation after axial motions by manual operation, the following motion takes place.

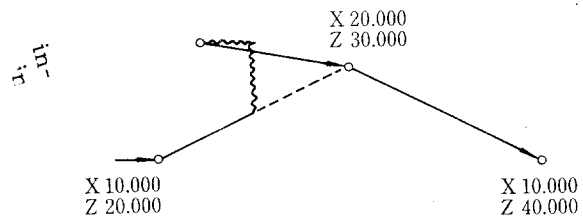

Fig. 18.9

18.2.11 SINGLE BLOCK (SBK) INPUT

This input is for executing part programs one block at a time in the automatic operation mode. With the control in the automatic operation mode, and the SBK input contact closed, when an automatic operation cycle is started, only one block of the part program is executed, and the machine stops. When the SBK input contact is closed during the execution of a part program, the control stops the machine after the execution of the current block.

For details of the use of single block during the execution of multiple cycles, user-macro programs, refer to "Operator's Manual for YASNAC LX1 (TOE-C843-7.20)."

18.2.12 OPTIONAL BLOCK DELETE (BDT, BDT2-BDT9) INPUT

This input is for determining whether data between "/" and "EOB" in a part program is executed or neglected when the part program contains "/."

Table 18.6

	Neglected Data between
BDT INPUT CLOSED	"/" or "/1" and "EOB" (End of block)
BDT 2 INPUT CLOSED	"/2" and "EOB"
BDT 3 INPUT CLOSED	"/3" and "EOB"
BDT 4 INPUT CLOSED	"/4" and "EOB"
BDT 5 INPUT CLOSED	"/5" and "EOB"
BDT 6 INPUT CLOSED	"/6" and "EOB"
BDT 7 INPUT CLOSED	"/7" and "EOB"
BDT 8 INPUT CLOSED	"/8" and "EOB"
BDT 9 INPUT CLOSED	"/9" and "EOB"

Note:

1. Data can be neglected only when part programs are executed. When storing or processing part programs, this input has no effect.
2. Whether data may be neglected or not depends on the state of the optional block delete input relay when the block containing "/" in a part program is stored in the buffer. Therefore, when controlling the optional block delete input relay by an external circuit with the use of the auxiliary function, take care to set the input state before the block containing "/" is stored in the buffer.

18.2.13 MACHINE LOCK (MLK) AND DISPLAY LOCK (DLK) INPUT

(1) MACHINE LOCK (MLK) INPUT

This is the input for preventing the outputting of control output pulses to the servo unit. While the MLK input contact is closed, even when the logic circuit distributes pulses in the automatic and manual operation modes, the machine does not move. As the logic circuits distribute pulses, the current value display changes with the instructions. If the MLK contact is closed or opened during the automatic operation of the control, the operation is not influenced until the start of the next block, and during manual operation, until the end of the current motion.

(2) DISPLAY LOCK (DLK) INPUT

This input is for preventing the output pulses of the control from being displayed on the external current value display. While the DLK input contact is closed, even when the machine is controlled automatically or manually, the external current value display (DRT, POS 1st display area "EXTERNAL," and external 2-axes current value display) does not change.

18.2.14 DRY RUN (DRN) INPUT

This input is for changing the feed rates of the tools during the execution of part programs in the automatic mode to the rates selected by the manual continuous feed selection inputs (FV1, 2, 4, 8 and 16).

While the DRN input contact is closed, the feedrates during the execution of part programs in the automatic mode are changed from the programmed ones to the ones selected by the manual continuous feed selection inputs.

While the DRN input contact is closed, the feedrates in part program execution in the automatic mode are the ones specified by the manual continuous feed selection input signals, instead of the programmed one. (However, for thread cutting, programmed feedrates remain effective.)

When the DRN input contact is closed or opened during the automatic operation of the control, the following change takes place.

During mm/rev feeding: No change of feedrate for the current block.

During mm/min feeding: Feedrate changes even during the current block.

NOTE

1. When parameter RPDDRN (#6006 D2) is set to 1, while the DRN input contact is closed, the feedrate in positioning command is changed to a manual continuous feedrate.
2. When parameter SCRDRN (#6019 D5) is set to 1, while the DRN input contact is closed, the feedrate is changed to a manual continuous feedrate.

18.2.15 CURRENT VALUE STORING (PSR) INPUT

This input is for storing current values in the control.

When the PST input contact is closed, the control stores current values (CRT screen POS display 1st area EXTERNAL) into the internal memory, and the LED incorporated in the OFS key in the MDI FUNCTION area flickers.

Then, it performs the following calculation on the offsets written by MDI, and stores the result in the offset memory.

$$\boxed{\text{Values to be written in offset memory}} = \boxed{\text{Input value}} - \boxed{\text{Current value stored in control}}$$

Resetting operation (depressing RESET key on MDI panel, or closing external reset input contact) cancels the current value storing mode and stops the flickering of the LED.

For the details of the usage of the PST input, refer to 5.2.3 Measured Workpiece Value Direct Input in YASNAC LX3 Operator's Manual (TOE-C843-9.20).

18.2.16 PROGRAM RESTART (PRST) INPUT

This input is used when a part program is to be started again after interruption. Close the PRST input contact, turn of the memory mode, and search the sequence No. of program restart by the NC operator's panel. The M, S, T codes present between the leading end of the program and the searched sequence No. are displayed on the CRT.

For the details of the usage of the PST input, refer to "5.2.6 Program Restart" in YASNAC LX3 Operator's Manual (TOE-C843-9.20).

18.2.17 EDIT LOCK (INHEDT)

This is the input for preventing the change of the contents of the stored part program. While the INHEDT input contact is closed, the following operations, among the ones in the program edit mode, are prohibited.

- Storing part programs by the MEM DATA "IN" key.
- The change, addition or deletion of part programs in the memory with the EDIT "ALT," "INS" and "ERS" keys.

18.2.18 AUXILIARY FUNCTION LOCK (AFL) INPUT

This is the input for omitting the M, S, T function in executing part programs in the automatic operation mode.

While the AFL input contact is closed, the control disregards M, S, T instructions of programs when executing part programs. However, M code decoded outputs (M00R, M01R, M02R, M30R) are outputted.

When the AFL input contact is closed or opened during the execution of part programs, the change becomes effective from the block subsequent to the current block.

NOTE

With S4-digit instructions analog outputs are output in accordance with the instructions, even while the AFL input contact is closed.

18.2.19 SETUP POINT RETURN (SRN) INPUT

This is the input for positioning the machine at the setup point by manual jogging.

While the SRN input contact is closed, manual jog motion stops as the machine arrives at the setup point. When the machine is at the setup point, manual jogging is impossible unless the SRN input contact is opened.

18.2.20 INTERRUPTION POINT RETURN (CPRN) INPUT

This is the input for positioning the machine at the interruption point by manual jogging after the control was switched over from the automatic operation mode to the manual operation mode, and subsequently moved away under manual control.

While the CPRN input contact is closed, manual jogging motion stops after arriving at the interruption point. When the machine is at the interruption point, manual jogging is impossible unless the CPRN input contact is opened.

18.2.21 OVERTRAVEL (*+LX, *-LX, *+LZ, *-LZ) INPUTS

These input signals are for signifying the arrival of the machine slides at their respective stroke ends. When these overtravel input contacts are opened, the machine slides stop motion, as shown in Table 18.7, and close the alarm (ALM) output contact and, at the same time, display alarm on the CRT.

Table 18.7

	Manual Operation Mode	Automatic Operation Mode
*+LX Input Opened	Motion stop in +X direction	Motion stop of all axes
*-LX Input Opened	Motion stop in -X direction	
*+LZ Input Opened	Motion stop in +Z direction	
*-LZ Input Opened	Motion stop in -Z direction	

When an overtravel input contact is opened, move the machine in the reverse direction in the manual operation mode (manual jogging or manual pulse generator) to close the contact, and then make the alarm output and display.

NOTE

Even when the overtravel input contacts are opened, the M code reading output (MF, S code reading output SF, and the T code reading output TF are not turned off. If the motion by M codes, S codes or T codes must be stopped by overtraveling inputs, interlock the motion with external sequence.

18.2.22 MACHINE-READY (MRD) INPUT

This input informs that the external heavy-current circuit is ready. When MRD input is closed after closing of Servo Power Input/Output (SVMX) from the power-on/off unit of the control after the power is turned on, the control is ready and "RDY" is displayed on the CRT screen.

When MRD input is opened with the control being ready, the control is put in the alarm state (alarm code "280" is displayed), thereby stopping the operation.

For the turning of power sequence, refer to "10 CONNECTION WITH POWER INPUT UNIT."

18.2.23 EMERGENCY STOP ON (*ESPS) OUTPUT

When Emergency-Stop Input (*TESP) is opened, *ESPS output is opened.

18.2.24 EXTERNAL RESET (ERS) INPUT AND RESET ON (RST1,2) OUTPUT

ERS is the input to reset the control. When ERS input is closed, the control stops all of its operations, closing Reset On outputs RST1 and RST2 for one second. The output signals are opened except for the following.

Table 18.8

Output Signals	Output at ERS Input Closed
AUT/MAN ZPX/ZPZ 2 ZPX/2 ZPZ *ESPS PO1-2 SO1-2	Previous conditions kept
RST1-2	Output contact is closed for one second while ERST input contact is closed or is opened.
ALM	Contact kept closed unless alarm causing factor is removed.
S11-S28 T11-T28 DS1-2 SINVA RO1-12 SDO0-15	Previous conditions kept.
TLCH1-2	Contact closed if any of selected, group of tools reaches end of life.
UO0-15	Previous conditions kept.

Note: When ERS input is closed, the control is put in the label skip state. However, memory is rewound, while the tape is not.

18.2.25 INTERLOCK (STLK) INPUT

This input stops the spindle travel in the automatic operation mode. When "STLK" input is closed during the spindle travel in the automatic operation mode, only the spindle travel is stopped with the automatic operation being activated ("STL" output is in the closed state). When "STLK" input is opened again, the spindle travel is resumed.

"STLK" input does not affect the M, S, and T commands in both manual and automatic operation modes.

18.2.26 ALARM (ALM) AND INPUT ERROR (IER) OUTPUTS AND EXTERNAL ERROR DETECT (ERR0,1) INPUTS

(1) ALARM (ALM) AND INPUT ERROR (IER) OUTPUTS

These outputs inform that the control is in the alarm state.

IER: This output is closed on detection of an alarm caused by the information from the part program or the input device. (Alarm codes "010" through "129.")

ALM: This output is closed on detection of any alarm other than the above. (However, the alarm for the fault of the logic circuitry in the control is not included.)

These outputs are opened again when the cause of the detected alarm has been removed and RESET operation is performed.

(2) EXTERNAL ERROR DETECT (ERR0, ERR1) INPUTS

These inputs put the control in the alarm state from the outside.

ERR0: When this input is closed, the control displays alarm code "180" and is put in the alarm state. If this input is closed during the execution of the part program in the automatic operation mode, the execution is stopped on completion of the block being executed.

ERR1: When this input is closed, the control displays alarm code "400" and is put in the alarm state. If this input is closed during the execution of the part program in the automatic operation mode, the tool travel is immediately slowed down and stopped.

18.2.27 RAPID THREADING PULL-OUT (CDZ) INPUT AND ERROR DETECT-ON (SMZ) INPUT

(1) RAPID THREADING PULL-OUT (CDZ) INPUT

This input determines whether rapid threading pull-out is performed or not in the execution of G92 (thread cutting cycle) or G76 (composite thread cutting cycle). When CDZ input is closed, the rapid threading pull-out is performed; when this input is open, it is not performed.

The control determines by the CDZ input whether rapid threading pull-out is performed or not at the start of a thread cutting cycle. To open/close CDZ input by such a command as M, add the delay time of the input circuit processing and set the state of CDZ input to the start of thread cutting cycle.

(2) ERROR DETECT GN (SMZ) INPUT

This input determines whether "Error Detect On" condition is added to the end conditions for the feed in the automatic operation mode.

"Error Detect On":

Due to the servo system delay, during travelling, the position detected by the position detector follows, the position designated by the logic circuit with a delay. When the designated position and the detected position are found under the values set in parameters XPSET and ZPSET (#6056 and #6057), it is called in the "Error Detect On" state.

When SMZ input is closed, "Error Detect On" condition is added to the feed end conditions in the automatic operation mode. When this input is open, this condition is not added.

SMZ input does not affect any positioning commands. (With each positioning command except G06 (Error Detect Off Positioning), "Error Detect On" condition is added to the end conditions.)

18.2.28 X-AXIS MIRROR IMAGE (MIX) INPUT

This input inverts the X-axis travelling direction in the automatic operation mode. When an automatic activation is performed with MIX input closed, the X-axis travelling direction by the part program is made opposite to the specified direction. When MIX input is closed then opened during the execution of the part program, it is made valid for the commands after the satisfaction of the following two conditions:

- (1) Compensation cancelled.
- (2) Out of automatic operation.

MIX input does not affect the X-axis travel in the manual operation mode.

18.2.29 M, S, AND T CODES (M11 THROUGH M38, S11 THROUGH S28, T11 THROUGH T28, MF, SF, TF, FIN) INPUTS/OUTPUTS

(1) M, S, AND T CODES OUTPUT AND M, S, AND T CODE READING OUTPUTS

Table 18.9

M code output	M11, M12, M14, M18, M21, M22, M24, M28, M31, M32, M34, M38
S code output	S11, S12, S14, S18, S21, S22, S24, S28
T code output	T11, T12, T14, T18, T21, T22, T24, T28
M code reading output	MF
S code reading output	SF
T code reading output	TF

These are outputs for the M, S, and T commands specified by the part program at its execution in the automatic operation mode. If any of M, S, and T commands is found at the execution of the part program in the automatic operation mode, the control outputs it in a BCD code according to the value that follows the detected command (M = 2 digits/3 digits, S = 2 digits, T = 2 digits).

Then, after the elapse of the time set in parameter MSTF (#6220), the M, S, and T code reading outputs are closed.

NOTE

1. With the S4 digit command, analog output is provided, disabling the S code output and the S-code read output.
2. M commands (M90 through M109) for logic circuit processing: With the T commands (T $\square\square\Delta\Delta$, T51 $\Delta\Delta$ through T80 $\Delta\Delta$, T90 $\Delta\Delta$, T $\square\square$ 90 through T $\square\square$ 95, and T $\square\square$ 99), the M/T code output and the M/T code reading output are not provided.

(2) M DECODE (M00R, M01R, M02R, AND M30R) OUTPUT

When any of M commands "M00," "M01," "M02," and "M30" is executed, the corresponding decoded output "M00R," "M01R," "M02R," or "M30R" is outputted in addition to the M code output and the M code reading output.

NOTE

When an M command for decoded output and a move command are specified in the same block, the M code output is provided at the start of the block, while the decoded output is provided after completion of the move command.

(3) M, S, AND T FUNCTIONS COMPLETION (FIN) INPUTS

These inputs give the completion of M, S, and T commands to the control. When FIN input is closed while the M, S, and T code reading (MF, SF, and TF) outputs are closed, they are opened. If FIN input is opened again after making sure of their opening, the control assumes that the M, S, or T command has been completed, starting the operation of the next step.

NOTE

1. For the S4-digit command, FIN input need not be closed.
2. When FIN input is closed then opened, the M code output and the M decoded output are all opened, but the S code and T code outputs remain without change.

18.2.29 M, S, AND T CODES (M11 THROUGH M38, S11 THROUGH S28, T11 THROUGH T28, MF, SF, TF, FIN) INPUTS/OUTPUTS (Cont'd)

(4) TIME CHART OF M, S, AND T SIGNALS

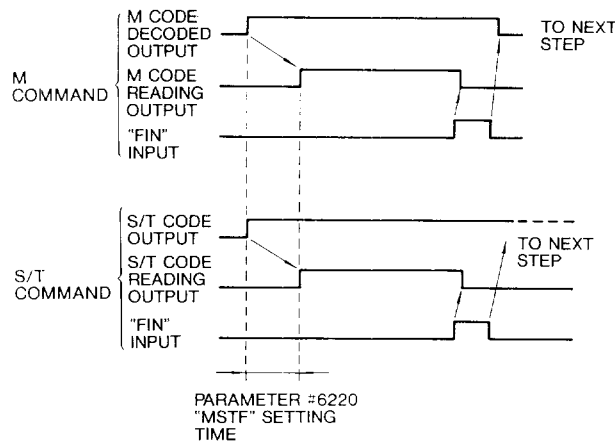

Fig. 18.10

If a move command and an M, S, or T command are specified in the same block, the move operation and the M, S, or T operation are executed simultaneously.

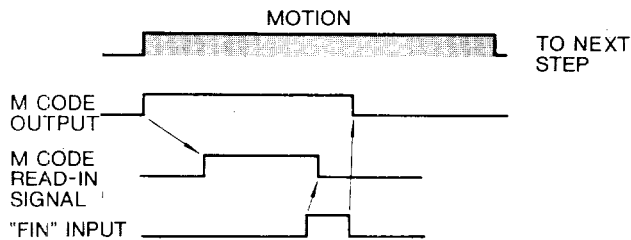

Fig. 18.11

18.2.30 POSITIONING COMPLETION (DEN1,2) OUTPUTS

These outputs inform the completion of a move command when an M, S, or T command and the move command have been specified in the same block at the execution of a part program in the automatic operation mode.

The block in which an M, S, or T command and a move command are specified at the same time is executed, if the M, S, or T command is not completed at the termination of the move command, positioning completion outputs DEN1 and DEN2 are closed.

When FIN input is closed then opened and the M, S, or T command is completed, the positioning completion outputs are opened.

18.2.31 TRAVEL ON (OP1,2) AND THREAD CUTTING ON (THC1,2) OUTPUTS

(1) TRAVEL ON (OP1,2) OUTPUTS

With these outputs, the control informs that the tool is traveling during the execution of a part program in the automatic operation mode. These outputs are closed in any of the following situations:

- During the execution of a move command.
- In the state in which a move command is discontinued by the interrupt (STLK) input or the FEEDHOLD (*SP) input.

(2) THREAD CUTTING ON (THC1,2) OUTPUTS

With these outputs, the control informs that thread cutting is being performed during the execution of part program in the automatic operation mode. These outputs are closed during thread cutting.

18.2.32 END-OF-PROGRAM (EOP) INPUT, REWIND (RWD) INPUT AND REWIND ON (RWDS1,2)OUTPUTS

(1) END-OF-PROGRAM (EOP) AND REWIND (RWD) INPUTS

With these outputs, the controller determines what processing is to be performed at completion of an M02 or M30 command. The control performs the following processing, depending on the state of EOP and RWD inputs, when completion input FIN for an M02R or M30R commands is opened and then closed:

In general, EOP input is connected to M02R output and RWD input, to M30R output.

Table 18.10

EOP	RWD	Function
1	1	The control is at standby after rewinding part programs and resetting programs
1	0	The control is at standby after resetting programs.
0	1	The control is at standby after rewinding part programs.
0	0	The control is at standby.

1: Closed, 0: Open

Note:

1. Program reset provides the same effects as with depressing of RESET key on MDI panel (ERS) input. In the program reset, however, the NC memory rewind operation is not performed. For details of the reset operation by closing ERS input, refer to 18.2.24 "EXTERNAL RESET (ERS) INPUT."
2. When a program reset operation is performed, Reset On output RST1 and RST2 are closed for one second.

(2) REWIND ON (RWDS1,2) OUTPUTS

With these outputs, the control informs that the part program is being rewound. If the part program is rewound by RWD input for an M02 or M30 command, RWDS1 and RWDS2 are closed during the rewinding operation.

NOTE

To use these outputs, set parameter RWDOUT (#6007, D4) to "1." Otherwise, they are not provided.

18.2.33 DISPLAY RESET (DRSX, DRSZ) INPUTS

These inputs set the external 2-axis current value display and the current value display on the operator's panel CRT to "0." When "DRSX" (X-axis display reset) or "DRSZ" (Z-axis display reset) is closed, "0" is set to the external 2-axis current value display and the current value display on the operator's panel CRT (the first screen "EXTERNAL").

18.2.34 EXTERNAL STORE, MATCH, AND OUTPUT (EIN, EVER, AND EOUT) INPUTS

These inputs are used to perform store, match, and output operations on the NC memory of the control from outside.

If these inputs are closed when the control is in the program edit mode and Edit Output On (EDTS) output is closed, the following operations take place:

EIN input is closed:

The part program is stored in the NC memory.

EVER input is closed:

The part program is matched against the NC memory.

EOUT is closed:

The contents of the NC memory are outputted.

While a store, match, or output operation is performed, the In-Edit (EDTS) output is closed.

NOTE

The I/O equipment for the store and match operations depends on setting IDVCE0, 1 and ODVCE0, 1 (#6003).

18.2.35 S4-DIGIT COMMANDS (DAS, SGS1, GR1 THROUGH GR4, SINV, AND SINVA) INPUTS/OUTPUTS

These signals are used to determine the speed of the spindle motor when the control is in the state of S Command 4-Digit Analog output.

GR1 through GR4 are used to enter into the control state of the gear range between the spindle and the spindle motor to determine the spindle motor speed by the spindle speed specified in the part program.

SINV input inverts the polarity of the analog output at the time of S Command 4-Digit Analog output.

While the polarity is inverted, SINVA signal is outputted.

(1) S4-DIGIT COMMAND ANALOG (GAS, SGS1) OUTPUT

Analog voltage (-10V to 0V to +10V) is outputted as follows by the spindle motor speed command and GR1 through GR4:

——— ; The output when "GR1" input is closed. (Set the spindle motor maximum speed at gear range "GR1" to parameter GR1REV: #6271.)

----- ; The output when "GR2" input is closed. (Set the spindle motor maximum speed at gear range "GR2" to parameter GR2REV: #6272.)

----- ; The output when "GR3" input is closed. (Set the spindle motor maximum speed at gear range "GR3" to parameter GR3REV: #6273.)

----- ; The output when "GR4" input is closed. (Set the spindle motor maximum speed at gear range "GR4" to parameter GR4REV: #6274.)

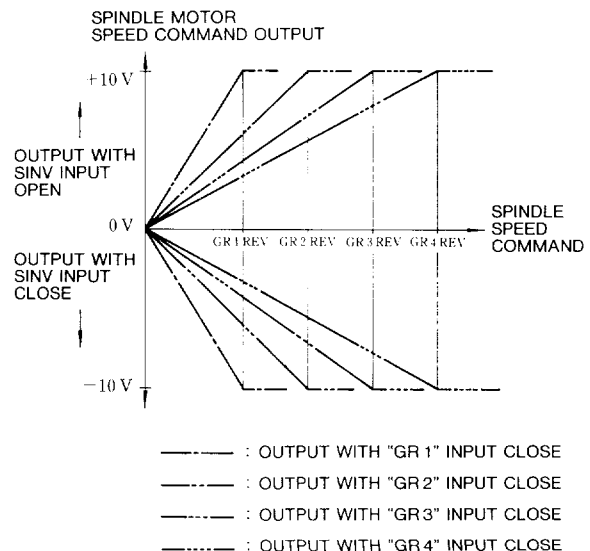

Fig. 18.12

18.2.35 S4-DIGT COMMANDS (DAS, SGS1, GR1 THROUGH GR4, SINV, AND SINVA) INPUTS/OUTPUTS (Cont'd)

(2) TIME CHART OF ANALOG VOLTAGE OUTPUT, SINV INPUT, AND SINVA OUTPUT FOR SPINDLE MOTOR SPEED

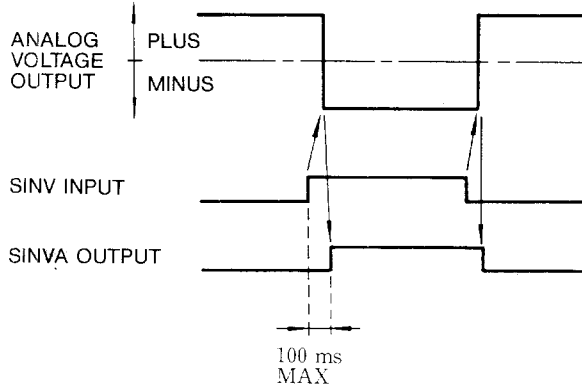

Fig. 18.13

(3) SPINDLE MAXIMUM/MINIMUM SPEED CLAMP

The spindle maximum/minimum speed at each gear range may be set using the following parameters:

Table 18.11

Parameter	Function	No. in Fig. below
MACGR1 (# 6266)	Spindle maximum speed when "GR1" input is closed.	V
MACGR2 (# 6267)	Spindle maximum speed when "GR2" input is closed.	VI
MACGR3 (# 6268)	Spindle maximum speed when "GR3" input is closed.	VII
MACGR4 (# 6269)	Spindle maximum speed when "GR4" input is closed.	VIII
MICGR1 (# 6276)	Spindle minimum speed when "GR1" input is closed.	I
MICGR2 (# 6277)	Spindle minimum speed when "GR2" input is closed.	II
MICGR3 (# 6278)	Spindle minimum speed when "GR3" input is closed.	III
MICGR4 (# 6279)	Spindle minimum speed when "GR4" input is closed.	IV

The following diagram shows an example of the S4-digit analog outputs when the spindle maximum/minimum speeds are clamped by these parameters:

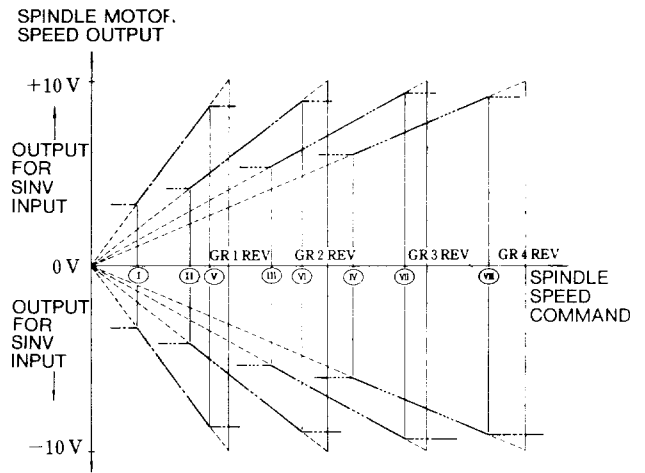

Fig. 18.14

Note:

- The spindle motor speed command output is obtained from the following relation:

$$(\text{Spindle speed command}) \times (10 \text{ V})$$

 (Spindle gear range spindle maximum speed determined by GR1 through GR4 inputs: parameters #6271 through #6274)
- With the spindle motor speed command analog output, the polarity may be inverted by processing M03 (spindle forward rotation) or M04 (spindle reverse rotation) within the control by using parameter SDASGN1 or SDASGN2 (#6006, D6 or D7).

Table 18.12

SDASGN1 (#6006, D6)	SDASGN2 (#6006, D7)	M03 Output	M04 Output
0	0	+	+
1	0	-	-
0	1	+	-
1	1	-	+

When SINV input is closed, the above polarities are inverted.

- When spindle S Command Stop (SSTP) input is closed, a value other than those described earlier may be outputted for the spindle motor speed command. For details, refer to "SPINDLE S COMMAND STOP (SSTP) INPUT."
- When two or more of GR1 through GR4 inputs are closed or not closed, the control determines the gear ranges as follows:

Table 18.13

GR1 Input	GR2 Input	GR3 Input	GR4 Input	Gear Range
0	0	0	0	Gear range 1
1	1	0	0	
1	0	1	0	
0	1	1	0	Gear range 2
1	1	1	0	
1	0	0	1	Gear range 1
0	1	0	1	
1	1	0	1	Gear range 1
0	0	1	1	
1	0	1	1	Gear range 1
0	1	1	1	
1	1	1	1	Gear range 1

0: Input open, 1: Input closed

Supplementary Explanation

Constant surface speed control and S4-digit command output:

When constant surface speed control (G96) is specified by the part program at its execution in the automatic operation mode, the output is varied every 100 ms according to the following relation during a cutting operation:

$$\frac{(\text{Surface speed by S command})}{(\text{X-axis current value}) \times (\pi)} \times (10 \text{ V})$$

(Spindle gear range max. speed determined by GR1 to GR4 inputs)

Time Chart Example

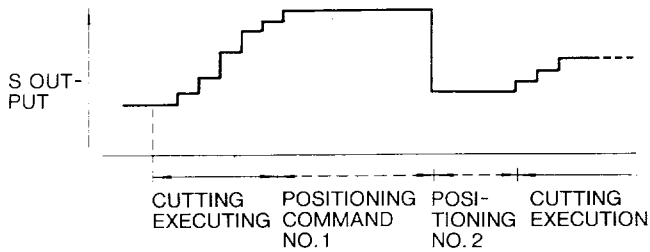

Fig. 18.15

Setting parameter POSG96 (#6020, D0) to "1" enables the control to perform the constant surface speed control also on the positioning command. (However, only the spindle speed obtained by the coordinate value of the positioning end point is outputted.)

18.2.36 SPINDLE S COMMAND "0" (SSTP), GEAR SHIFT ON (GRS) INPUT, AND SPINDLE CONSTANT SPEED (GSC) INPUT

These inputs are used to make the S4-digit command analog output provide the outputs other than the part program S command. When SSTP input is closed, the spindle motor speed command output based on the spindle speed specified in the part program is stopped.

If GRS input is closed in this state, the voltage to set to parameter GRSREV (#6270) is outputted.

If GSC input is closed, the spindle motor speed command voltage is outputted which corresponds to the spindle speed to be set to parameter GSCREV (#6275) by the spindle gear range input.

Table 18.14

SSTP Input	GRS Input	GSC Input	S4-digit Command Analog Voltage
0	0	0	Voltage corresponding to spindle speed commanded by NC program.
0	0	1	
0	1	0	
0	1	1	
1	0	0	0 V
1	0	1	Voltage corresponding to parameter GSCREV.
1	1	0	Parameter GRSREV setting value.
1	1	1	0 V

0: Contact open, 1: Contact closed

Note

1. It is possible to make the analog outputs for SSTP, GRS, and GSC inputs negative by the S4-digit analog output invert (SINV) input.
2. The period of time between the setting of SSTP, GRS, or GSC input and the catching-up of the analog voltage value is shorter than 100 ms.
3. Setting parameter SSTPAB (#6020, D4) to 1 enables the control to provide "*"SSTP" input.

18.2.37 SPINDLE SPEED REACHED (SAGR) INPUT

This input is used to inform, in the case of the S4-digit command, that the spindle speed has reached the specified value at the start of cutting at the execution of the part program in the automatic operation mode. At the start of cutting (when switching from a positioning command to a cutting command takes place), the control delays the time by the value specified in parameter SAGR (#6224), makes sure that SAGR input is closed, and starts cutting.

NOTE

1. To perform the above operation by SAGR input, set parameter SAGRCH (#6006, D4) to "1." If it is set to "0," SAGR input is ignored.
2. In G96 mode, SAGR input is checked every time the switching from a positioning command to a cutting command takes place. In G97 mode, SAGR input is checked at the switching only when the spindle speed is different between the positioning start and end times.

18.2.38 SPINDLE SPEED OVERRIDE (SPA, SPB, SPC, SPD AND SPE) INPUTS

These inputs are used, in the case of the S4-digit command, to override the S command in a range of 50% to 120% at the execution of the part program in the automatic operation mode.

18.2.38 SPINDLE SPEED OVERRIDE (SPA, SPB, SPC, SPD AND SPE) INPUTS (Cont'd)

Table 18.15

SPA Input	SPB Input	SPC Input	Override to S Command
1	1	1	50 %
0	1	1	60 %
0	1	0	70 %
1	1	0	80 %
1	0	0	90 %
0	0	0	100 %
0	0	1	110 %
1	0	1	120 %

1: Closed, 0: Open

Override is specified to S command within 10% to 200% range by parameter #6018 D1.

Input					Override to S Command
SPA	SPB	SPC	SPD	SPE	
0	0	0	1	0	10 %
0	0	1	1	0	20 %
0	1	1	1	0	30 %
1	1	1	1	0	40 %
1	1	1	0	0	50 %
0	1	1	0	0	60 %
0	1	0	0	0	70 %
1	1	0	0	0	80 %
1	0	0	0	0	90 %
0	0	0	0	0	100 %
0	0	1	0	0	110 %
1	0	1	0	0	120 %
1	0	1	1	0	130 %
1	0	0	1	0	140 %
1	1	0	1	0	150 %
0	1	0	1	0	160 %
0	1	0	1	1	170 %
0	1	0	0	1	180 %
0	0	0	0	1	190 %
1	0	0	0	1	200 %

1: Closed, 0: Open

18.2.39 S4-DIGIT COMMAND EXTERNAL OUTPUTS (SDO0 THROUGH SDO15) AND S4-DIGIT EXTERNAL INPUTS (SDI0 THROUGH SDI15)

These inputs and outputs are used, when the control is of S command 4-digit, to output the results of the operation by the S command in the part program to the outside and perform the actual S4-digit command analog output according to the inputs from the outside.

(1) S4-DIGIT COMMAND ANALOG OUTPUT

- Output of operation results to outside: SDO0 through SDO15
- Inputs from outside to output analog voltage to DAS and SGS1: SDI0 through SDI15

Note: The input/output value is a signed binary 16-bit. The relationship with analog voltages is as follows: -32767 to 0 to +32768, -10 V to 0 to +10 V

NOTE

The primary purpose of this function is to control the S4-digit command by the sequencer built in the control. This function should not be used for other purposes unless especially required.

18.2.40 EXTERNAL WORK NUMBER SEARCH A (WN1, WN2, WN4, WN8, AND WN16) INPUTS

This is a function to select the program by the program number specified by external input from the part programs stored in the part program memory of the equipment.

(1) To use this external work number search A, assign the program number as follows:

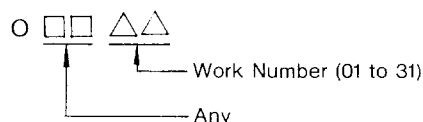

The work number search timing is as follows (provided that the external input (WN1 to WN16) is not "00"):

- A reset operation. (When RESET key is pressed, or the external reset input or EOP input is turned on.)
- When CYCLE START key is pressed in the memory mode and the label skip on state.

(2) The relationship between external inputs WN1 through WN16 and program numbers is as shown in Table 18.16.

Table 18.16

Program No.	Input State				
	WN1	WN2	WN4	WN8	WN16
□□01	1	0	0	0	0
□□02	0	1	0	0	0
□□03	1	1	0	0	0
□□04	0	0	1	0	0
□□05	1	0	1	0	0
□□06	0	1	1	0	0
□□07	1	1	1	0	0
□□08	0	0	0	1	0
□□09	1	0	0	1	0
□□10	0	1	0	1	0
□□11	1	1	0	1	0
□□12	0	0	1	1	0
□□13	1	0	1	1	0
□□14	0	1	1	1	0
□□15	1	1	1	1	0
□□16	0	0	0	0	1
□□17	1	0	0	0	1
□□18	0	1	0	0	1
□□19	1	1	0	0	1
□□20	0	0	1	0	1
□□21	1	0	1	0	1
□□22	0	1	1	0	1
□□23	1	1	1	0	1
□□24	0	0	0	1	1
□□25	1	0	0	1	1
□□26	0	1	0	1	1
□□27	1	1	0	1	1
□□28	0	0	1	1	1
□□29	1	0	1	1	1
□□30	0	1	1	1	1
□□31	1	1	1	1	1

1: Closed, 0: Open

Note:

- WN1 through WN16 inputs are disregarded at the start of a part program in other than memory and running modes. The start of a part program is when an automatic run is activated in the label skip state ("LSK" is being displayed on the CRT screen).
- The program number selection by a reset operation is performed independently of the running mode.
- When WN1 through WN16 inputs are all open, the program number selection is not performed.
- If the part program memory of the control contains two or more part programs which have part program numbers 01 through 31 specified by WN1 through WN16, the program stored nearest the memory beginning is selected.
- The program numbers for which this search function is valid are 0 □□ 01 through 0 □□ 31.
- If the specified program number is not found after a search operation, error "134" is caused.
- When this work number search A function is performed, FUNCTION is automatically changed to PROG.

18.2.41 TIME COUNT (EXTC) INPUT (OPTIONAL)

This input makes the control count the time. The control accumulates the time in which EXTC input is closed and displays the result in the bottom of "OPERATION TIME DISPLAY," which is on page 3 of "ALM" function on the operator's station CRT. (Operating time display "EXTERNAL" is optional.) The time display is reset by pressing "4" key then **ORG** key by the MDI. Until this reset operation is performed, the time display is retained after such an operation as power-on.

18.2.42 SPINDLE INDEXING FUNCTION (SID1-SID12) INPUT/OUTPUT

This input/output is used perform the spindle indexing function which stops the spindle at the desired position by controlling the S4-digit analog output by the pulse from the spindle pulse generator.

(1) INPUT SIGNALS

- SID1 through SID12:

Binary 12-bit (0 to 4095) input signals to specify the spindle stop position. Each signal corresponds to the pulse (4096 pulses/rev) from the spindle pulse generator. Usually, the stop position corresponds to the number of pulses entered by SID1 to SID12 from C-phase pulse (1 pulse/rev) of the spindle pulse generator.

Note: Use of parameter SIDREF (#6342) enables the control to shift the stop position by the number of pulses set from C-phase pulse to this parameter.

- SIDX:

The input signal to request the control for a spindle indexing operation. If this input is closed while the spindle is rotating, the speed command to perform indexing is output and the spindle indexing operation is started.

After the completion of the indexing operation, the spindle speed command analog output remains a spindle positioning command unless this input is turned off. Thereby making the control continue the indexing operation.

- SIDXI and SIDXINC:

SIDXI (spindle indexing restart input) and SIDXINC (spindle stop position designate incremental input) are the inputs for the repetitive spindle indexing sequence. For details, refer to (6) INPUTS FOR SPINDLE INDEXING EXTENSION FUNCTION.

(2) OUTPUT SIGNALS

- SIDXO:

This output goes on when the control is performing a spindle indexing operation (during the output of creep speed command or spindle positioning command).

18.2.42 SPINDLE INDEXING FUNCTION (SID1-SID12) INPUT/OUTPUT (Cont'd)

• SIDXA:

This signal indicates the completion of a spindle indexing operation. It is on while the spindle position is in the range between the position set in parameter SPSET (#6058) and the position designated by SID1 to SID12.

(3) SPINDLE INDEX TIME CHART

- Spindle index by M-code at spindle stop (Spindle positioning is released after spindle index is completed.) See Fig. 18.16.
- Spindle index by M code at spindle forward operation (Spindle positioning is continued until next spindle speed command after spindle index is completed.) See Fig. 18.17.

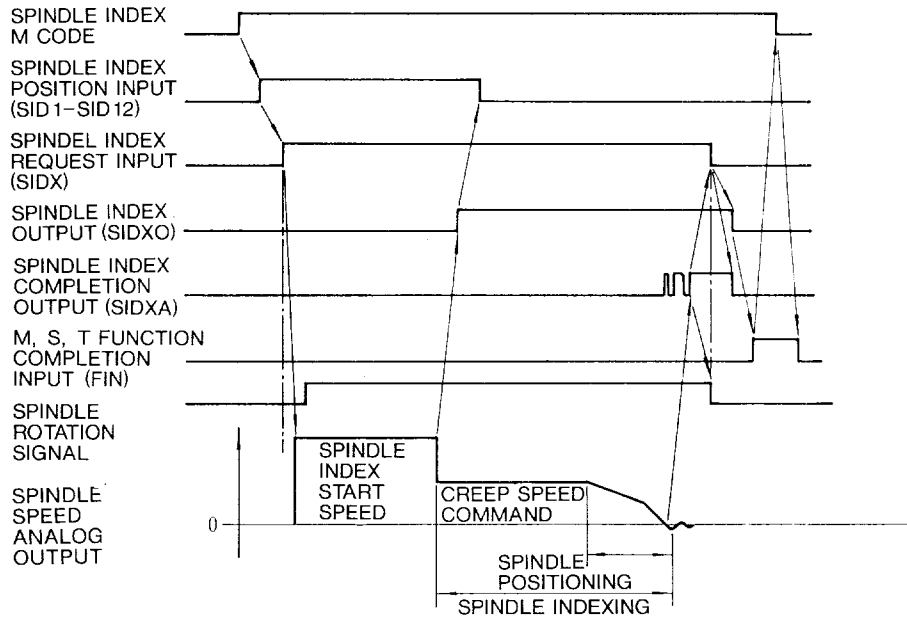

Fig. 18.16

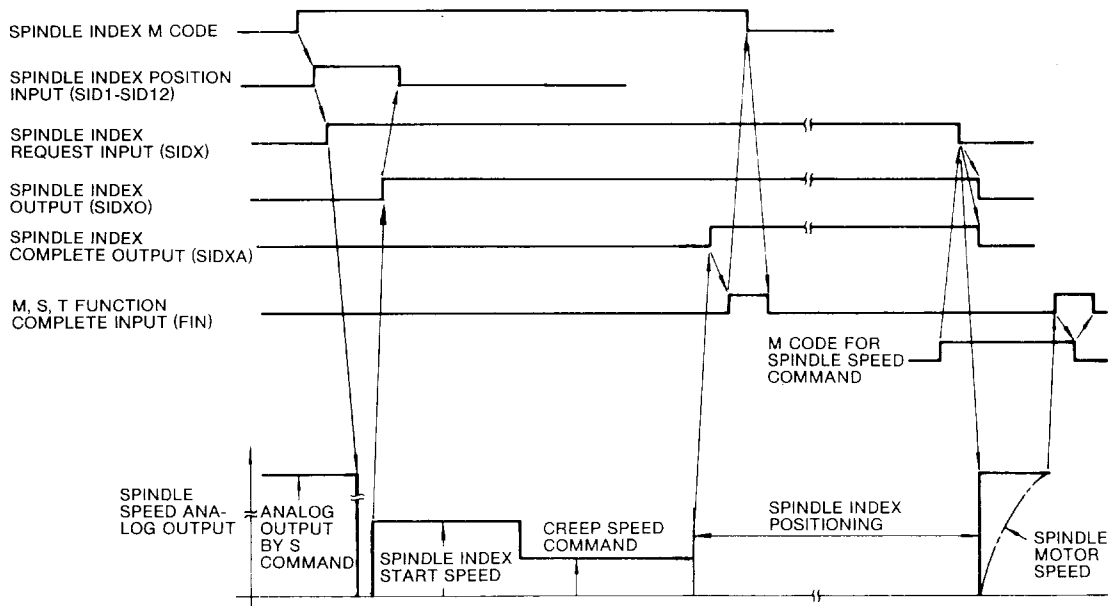

Fig. 18.17

(4) PARAMETERS FOR SPINDLE INDEXING AND DETAILED SPINDLE INDEXING

Table 18.17

No.	Detailed Function of Spindle Indexing	Setting
# 6058 (SPSET)	Pulse width of index completion output signal.	1 = 1 pulse
# 6064 (BSS)	Bits setting for output saturation	Refer to parameter table.
# 6076 (SSVER)	Servo alarm area setting for spindle drive	Refer to parameter table.
# 6085 (SIDSER)	Timer setting to confirm the spindle stop	1 = 8 ms
# 6342 (SIDREF)	Spindle index reference point setting	1 = 1 pulse
# 6343 (SIDRV1)	Spindle index speed command	1 = 500 pps
# 6344 (SIDCRP)	Spindle index creep speed command	1 = 500 pps
# 6227 (KPS)	Position loop gain	Set 1024.

Note: 1 pulse = $0.088^\circ \left(\frac{360^\circ}{4096 \text{ pulses}} \right)$

(5) DISPLAY OF SPINDLE INDEXING FUNCTION

When the control contains the spindle indexing option, the following display is made under heading SPINDLE COUNTER on page 8 of the POSITION display on CRT screen:

- During a spindle indexing operation (SIDXO output is on), the number of pulses from the spindle pulse generator is displayed.

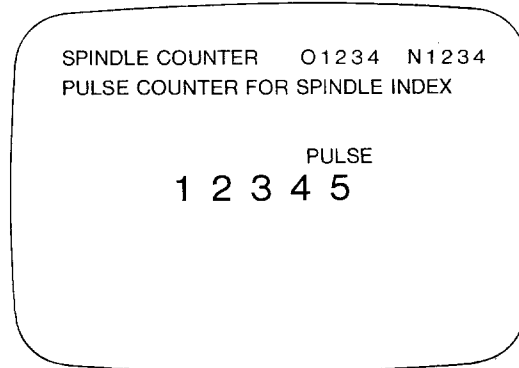

- When a spindle indexing operation is not performed (SIDXO output is off), the spindle speed (obtained by converting the number of pulses from the spindle pulse generator) is displayed.

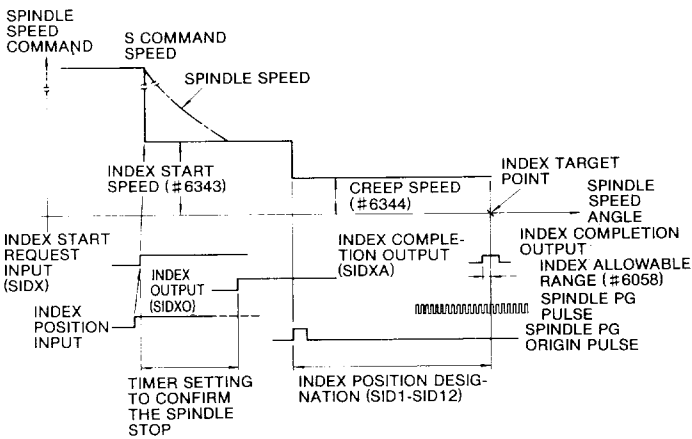
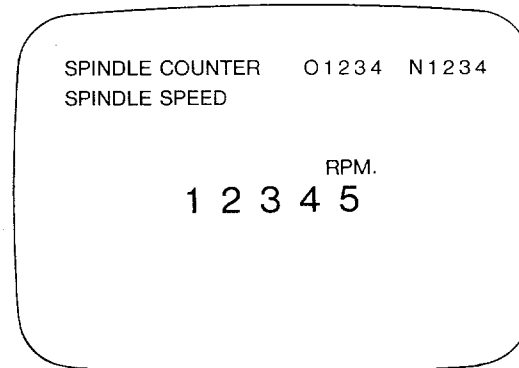

Fig. 18.18 Detailed Spindle Indexing

18.2.42 SPINDLE INDEXING FUNCTION (SID1-SID12) INPUT/OUTPUT (Cont'd)

(6) SPINDLE INDEXING EXTENSION FUNCTION INPUT

The control provides the following two inputs to process various spindle indexing sequence made available by application of the spindle indexing function described previously.

• SIDXI:

Spindle indexing restart input. If this input is closed with Spindle Indexing On (SIDXO) output on, the control stops the spindle indexing operation and turns the SIDXO output off. While the indexing operation is discontinued, the spindle speed command analog output becomes the spindle indexing start speed command.

When this input is turned off in this state, the control restarts the spindle indexing operation.

• SIDXING:

Spindle indexing position incremental input. This input is used to designate an incremental position of the spindle indexing position input (SID1 to SID12) from its previously designated position.

The use of this input enables the control to rotate the spindle from the current indexing position to the next indexing position without a full rotation. However, this input is invalid when the spindle indexing operation is first made after rotating the spindle in non-indexing operation or when the spindle indexing operation is first made after the power-on operation.

• Example of Spindle Indexing Time Chart using Spindle Indexing Extension Input:

(i) Restart the spindle index if spindle index is not completed, the specified time after spindle indexing (Fig. 18.19).

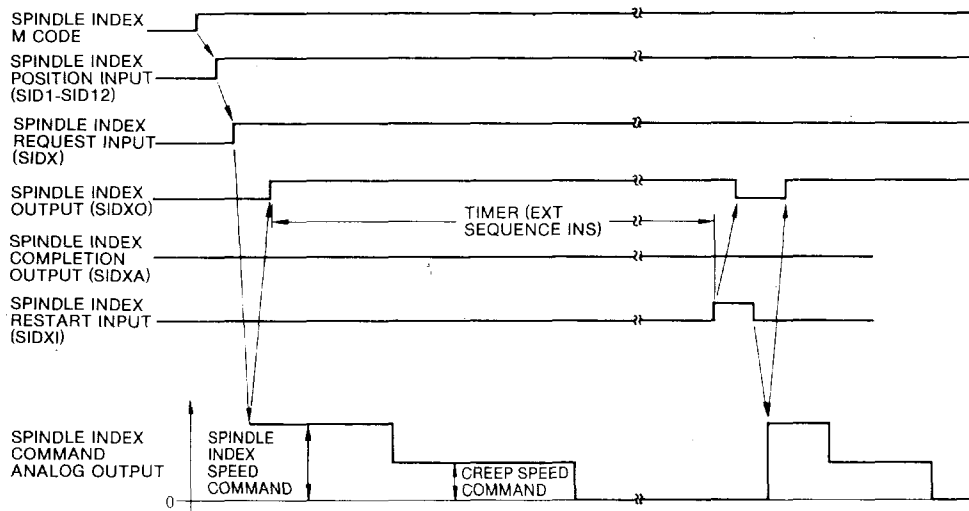

Fig. 18.19

(ii) Spindle indexing at A position 180° from the indexed position after spindle indexing and mechanical clamp and machining. See Fig. 18.20.

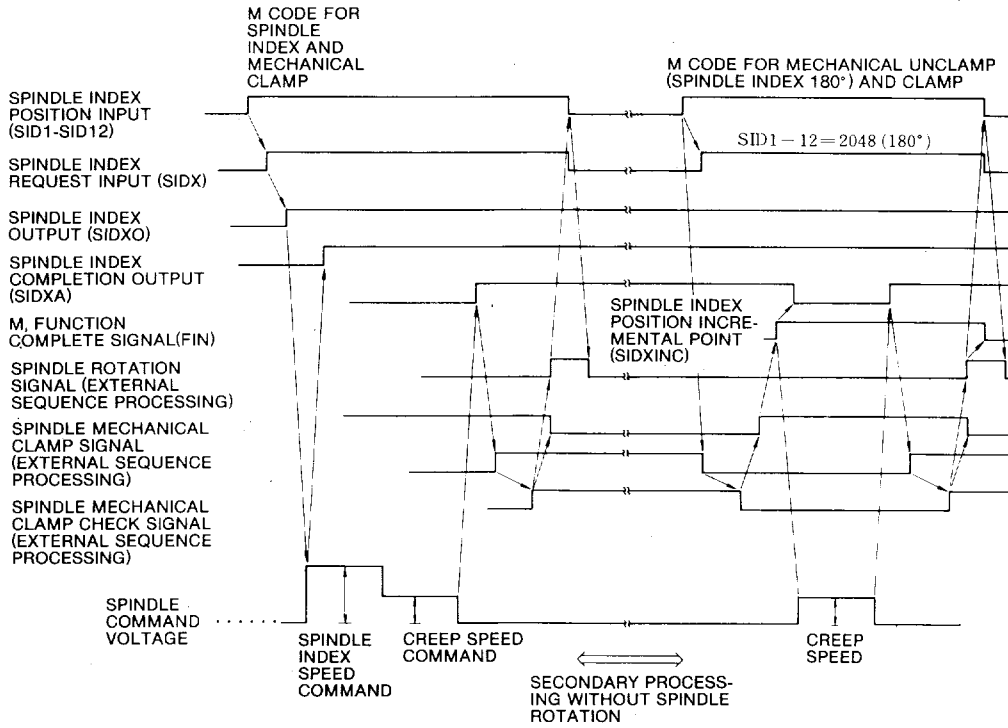
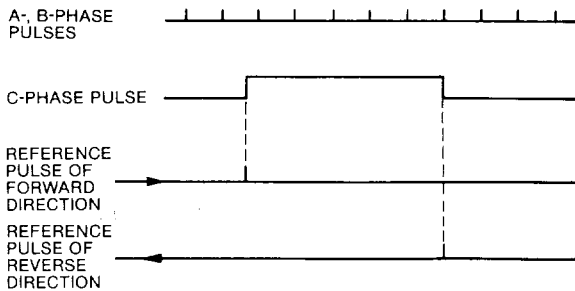

Fig. 18.20

Note:

1. The spindle indexing function is available only when the control has the S command 4-digit analog output specification. The polarity of S 4-digit analog output should be externally determined by SIN V input.
2. To make a spindle index from the spindle reverse rotating state, keep SIN V input on while the spindle indexing request input (SIDX) is on.
3. When an incremental spindle indexing operation is performed by turning SIDXINC input on with SIN V input being on, the direction of the increment specified by SID 1 to SID 12 is reversed.
4. A spindle indexing operation is not performed during interpolation pulse output.
5. Accumulated values of pulses by incremental command should be 10 pulses or less.
6. Spindle index is performed at the edge of C-phase pulse (1 pulse/rev) as a reference pulse. When C-phase pulse includes a pulse width as shown below, a spindle index position between the spindle forward and reverse rotating states is shifted by C-phase pulse width.



18.2.43 STORED STROKE LIMIT 3 BY TOOL (TP1, TP2, TP4, TP8, TPS, TPSA1 AND TPSA2) INPUTS/OUTPUTS

(1) Using the following input/output signals, this function sets a maximum of 15 types of stored stroke limit 3 as classified by tool. This is by the use of the external input:

- Tool number input --- TP1, TP2, TP4, and TP8
- Area change input --- TPS
- Area change complete input --- TPSA1 and TPSA2

18.2.43 STORED STROKE LIMIT 3 BY TOOL (TP1, TP2, TP4, TP8, TPS, TPSA1 AND TPSA2) INPUTS/ OUTPUTS (Cont'd)

(2) At the power-on, reset operation, or closing TPS input, the control selects the stored stroke limit area as follows according to TP input:

Table 18.18

Input State				Parameter No. Setting Area
TP1	TP2	TP4	TP8	
1	0	0	0	# 6508 - # 6511
0	1	0	0	# 6512 - # 6515
1	1	0	0	# 6516 - # 6519
0	0	1	0	# 6520 - # 6523
1	0	1	0	# 6224 - # 6527
0	1	1	0	# 6528 - # 6531
1	1	1	0	# 6532 - # 6535
0	0	0	1	# 6536 - # 6539
1	0	0	1	# 6540 - # 6543
0	1	0	1	# 6544 - # 6547
1	1	0	1	# 6548 - # 6551
0	0	1	1	# 6552 - # 6555
1	0	1	1	# 6556 - # 6559
0	1	1	1	# 6560 - # 6563
1	1	1	1	# 6564 - # 6567

1: Closed, 0: Open

(3) When the TPS input is closed, the control performs the area change, upon completion of which area change outputs TPSA and TPSA2 are closed.

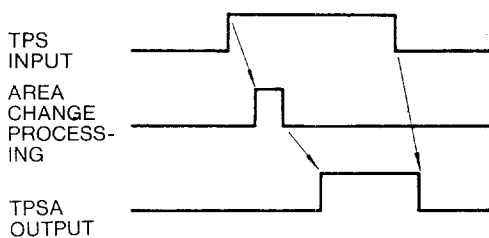

Fig. 18.21

If the TPS input is turned on during the spindle shift in the auto or manual mode, the area change processing is not performed.

18.2.44 MACRO PROGRAM (UI0-UI15, UO0-UO15) INPUT/OUTPUT FUNCTION

These inputs/outputs are used as system variables in macro programs:

Table 18.19

System Variables	Input	System Variables	Output
# 1000	UI 0	# 1100	UO 0
# 1001	UI 1	# 1101	UO 1
# 1002	UI 2	# 1102	UO 2
# 1003	UI 3	# 1103	UO 3
# 1004	UI 4	# 1104	UO 4
# 1005	UI 5	# 1105	UO 5
# 1006	UI 6	# 1106	UO 6
# 1007	UI 7	# 1107	UO 7
# 1008	UI 8	# 1108	UO 8
# 1009	UI 9	# 1109	UO 9
# 1010	UI 10	# 1110	UO 10
# 1011	UI 11	# 1111	UO 11
# 1012	UI 12	# 1112	UO 12
# 1013	UI 13	# 1113	UO 13
# 1014	UI 14	# 1114	UO 14
# 1015	UI 15	# 1115	UO 15

18.2.45 EXTERNAL DATA INPUT (ED 0 THROUGH ED15, EDSA THROUGH EDSO, EDSA 0 THROUGH EDSA2, EDCL, EREND, AND ESEND) INPUTS/ OUTPUTS

(1) These inputs/outputs are used to make the machine perform the following functions by external inputs.

- a. External work number search C
Search for a 4-digit program number.
- b. External tool compensation C
Modification of a 4-digit tool offset.
- c. External work coordinate system shift

There are following input signals:

- Data input --- ED0 through ED15.
- Data designation input --- EDSA through EDSO.
- Axis designation --- EDAS0 through EDAS2.
- Data request input --- EDCL.

The details of these input signals are as shown in Table 18.20.

Table 18.20

Item Signal Name	External Work No. Search C	External Tool Compensation C
ED 0	Program No. No. of 1-digit (BCD code)	Compensation amount No. of 1-digit (BCD code)
ED 1		
ED 2		
ED 3		
ED 4	No. of 10-digit	No. of 10-digit
ED 5		
ED 6		
ED 7		
ED 8	No. of 100-digit	No. of 100-digit
ED 9		
ED 10		
ED 11		
ED 12	No. of 1000- digit	No. of 1000-digit (0 to 7)
ED 13		
ED 14		
ED 15		
EDSA	1	0
EDSB	0	1
EDSC	0	0
EDSD	0	0
EDAS 0	0 or 1	Axis designation 0: X, 1: Z
EDAS 1	0 or 1	0
EDAS 2	0 or 1	0: Incremental 1: Absolute
EDCL	Data read-in request	

1: Closed, 0: Open

There are the following output signals:

- External data input complete --- EREND
- External data search complete --- ESEND

(2) EXTERNAL WORK NUMBER SEARCH C

This function searches for the part program of a 4-digit program number designated by the input signal ED0 to ED15. The timing of signal transfer is as follows:

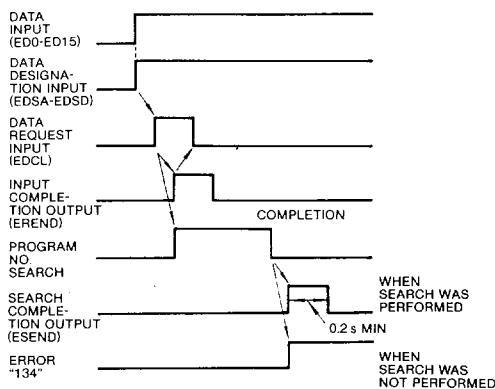

Fig. 18.22

- EDCL input is detected by the 8 ms scan.
- When EDCL goes on, EREND is output within 8 ms, starting the search for the part program of the designated program number.
- If the desired program has been found, ESEND is output for more than 200 ms. However, this signal is not output when the Reset On output is on. It is output only when this output is turned off.
- If the desired program has not been found, error "134" is caused and ESEND is not outputted.

NOTE

This external work number search function is valid only in the memory mode and the label skip state. In any other conditions, EDCL input is invalid.

(3) EXTERNAL TOOL COMPENSATION C

This function adds or replaces the tool offset (0 to ±7.999 mm or 0 to ±0.7999 in.) designated by input ED0 to ED15 to or with the currently designated tool offset memory value. When EDAS2 is "0," addition is made; when it is "1," replacement is made. The timing of signal transfer is as shown in Fig. 18.23.

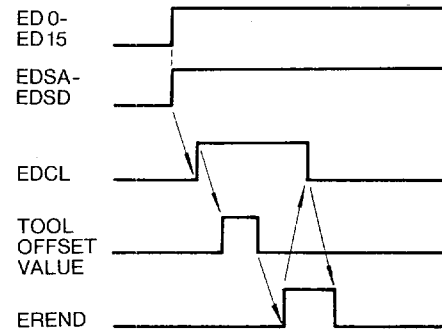

Fig. 18.23

- EDCL input is detected by the 8 ms scan.
- The tool offset number to be rewritten is the currently designated tool offset number. At the time of single block stop, the contents of the tool offset number of the terminated block are rewritten.

(4) EXTERNAL WORK COORDINATE SYSTEM SHIFT

When the currently designated tool offset number is "00" in the external tool compensation C, this function adds or replaces the value (0 to ±7.999 mm or 0 to ±0.7999 in.) designated by input ED0 to ED15 to or with the work coordinate system memory value. When EDAS2 is "0," addition is made; when it is "1," replacement is made. The timing of signal transfer is the same as with the external tool compensation C.

18.2.45 EXTERNAL DATA INPUT (ED 0 THROUGH ED15, EDSA THROUGH ESD, EDSA 0 THROUGH EDSA2, EDCL, EREND, AND ESEND) INPUTS/OUTPUTS

Generally, the external tool compensation C and external work coordinate system shift functions must be activated by specifying a given M code in an appropriate location on the part program and turning on the data request input EDCL by that M code.

18.2.46 TOOL LIFE CONTROL (TLA1 THROUGH TLA16, TLTM, TLSKP, TLRST, TLCH1 AND TLCH2) INPUTS/OUTPUTS

The tool life control function enters the following into the control: the information on tool life (how long a tool is serviceable or how many workpieces a tool can cut), the tool numbers of tool groups of the same type and the compensation numbers to be used. This makes it possible, by simply specifying the T code for tool life control in the part program, for the control to control that T code according to the machining time and the number of workpieces entered.

Described here are only the signals associated with this function. For the program and other information, refer to "YASNAC LX3 Operator's Manual (T0E-C843-9.20)."

This function uses the following inputs/outputs:

- Tool replacement completion tool group number inputs --- TLA11, TLA12, TLA14, TLA18, and TLA21.
- Tool skip input --- TLSKP.
- Tool replacement request outputs --- TLCH1 and TLCH2.

It is also needed to make a registration of the following information through the program tape or operator's panel MDI operation:

Table 18.21 Registration of Tool Groups

Setting Number	Registration
# 8601	Tool group number tool number "01." Setting 1 to 19.
to	to
# 8650	Tool group number of tool number "50." Setting value 1 to 19.

Table 18.22 Registration of Tool Life

Setting Number	Registration
# 6161	Life of tool group "01."
to	to
# 6169	Life of tool group "09." Machining count setting: 1 = once.
# 6170	Life of tool group "10."
to	to
# 6179	Life of tool group "19." Machining time setting: 1 = 1 min.

In addition, there are settings for registering compensation numbers and other information. Since they have no relation to the input/output, the explanation is omitted.

(1) TOOL REPLACEMENT COMPLETE TOOL GROUP NUMBER INPUTS (TLA1, TLA2, TLA4, TLA8, AND TLA16) AND TOOL REPLACEMENT COMPLETE INPUT (TLRST)

These inputs inform the control of the completion of tool replacement after the replacement of the tools of the group number whose life has terminated.

Set the tool group number of tool replacement complete to TLA1, TLA2, TLA4, TLA8, and TLA16 according to Table 18.23, and close TLRST input.

When the replacement of the tools of the group number whose life has terminated is all completed, tool replacement request outputs TLCH1 and TLCH2 are opened.

Table 18.23

Input					Tool Change Completion Group No.
TLA1	TLA2	TLA4	TLA8	TLA16	
1	0	0	0	0	01
0	1	0	0	0	02
1	1	0	0	0	03
0	0	1	0	0	04
1	0	1	0	0	05
0	1	1	0	0	06
1	1	1	0	0	07
0	0	0	1	0	08
1	0	0	1	0	09
0	1	0	1	0	10
1	1	0	1	0	11
0	0	1	1	0	12
1	0	1	1	0	13
0	1	1	1	0	14
1	1	1	1	0	15
0	0	0	0	1	16
1	0	0	0	1	17
0	1	0	0	1	18
1	1	0	0	1	19

1: Closed, 0: Open

(2) TOOL SKIP INPUT (TLSKP)

This input is used to replace registered tools before their service lives terminate.

When TLSKP input is closed in the automatic feedhold state (STL and SPL outputs are open), the processing that the service life of the currently used tool has terminated is performed within the controller. Then the new tool is specified by the following T command.

(3) TOOL REPLACEMENT REQUEST OUTPUTS (TLCH1 AND TLCH2)

When a program end or reset operation is performed after the termination of the service lives of all registered tools belonging to a tool group number, TLCH1 and TLCH2 are closed.

When these outputs are closed, make sure of the tool group number which is being displayed on the CRT screen and replace the tools.

NOTE

When TLCH1 and TLCH2 are closed, the automatic activation in the automatic operation mode is disabled.

18.2.47 SKIP INPUT

If SKIP input is closed during the execution of move command by G31 in the automatic operation mode, the control immediately stops the movement and stores the coordinate value where SKIP input changed from open to close. At this point, the block of G31 command is regarded to have been completed, and the following block is taken up.

The coordinate value of the skip position is stored in the following setting numbers:

- #6568 --- X-axis coordinate value
- #6569 --- Z-axis coordinate value

NOTE

1. The block of G31 command moves in the same way as G01. If parameter SKPFED (#6019, D4) is set to "1," the feed rate which is not specified in the part program but is set to parameter G31F (#6232) is provided.
2. If SKIP input is not closed after the completion of the block of G31 command, the following operation takes place:
 - . When setting SKIPIN (#6004, D0) is set to "1," the following block is executed.
 - . When setting SKIPIN (#6004, D0) is set to "0," the alarm state (alarm code "087") is generated.

18.2.48 COMBINED FIXED CYCLE CUTTING OVERRIDE (COV1, COV2, COV4, COV8, AND COV16) INPUTS

These inputs are used to override the cut depth of the stock removal cycle specified by G71 and G72. According to the state of these inputs, an override is applied to the cut depth specified in "D."

Table 18.24

Input					Override (%)
COV1	COV2	COV4	COV8	COV16	
0	0	0	0	0	0
1	0	0	0	0	10
0	1	0	0	0	20
1	1	0	0	0	30
0	0	1	0	0	40
1	0	1	0	0	50
0	1	1	0	0	60
1	1	1	0	0	70
0	0	0	1	0	80
1	0	0	1	0	90
0	1	0	1	0	100
1	1	0	1	0	110
0	0	1	1	0	120
1	0	1	1	0	130
0	1	1	1	0	140
1	1	1	0	0	150
0	0	0	0	1	160
1	0	0	0	1	170
0	1	0	0	1	180
1	1	0	0	1	190
0	0	1	0	1	200

1: Closed, 0: Open

18.2.49 SERVO POWER ON (SONPB) INPUT

- (1) If this input is closed when NC power is on (NCMX is on), servo power turns on by power-on operation.
- (2) This input is equivalent to turning on servo power by the power on pushbutton.
- (3) This input is effective if parameter #6030 D4 = 1. If this parameter is selected, the power on pushbutton cannot turn on servo power.

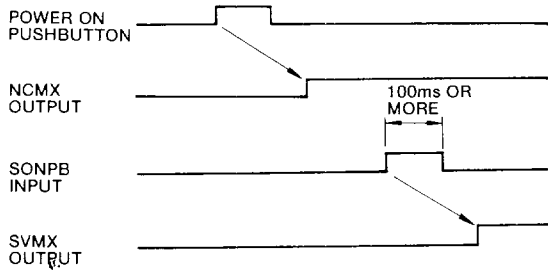

Fig. 18.24

18.2.50 HIGH-SPEED REWIND AND START (RWDH) INPUT

- (1) NC performs high-speed rewinding by closing this input and by returning a completion signal (FIN) during execution of M30.
- (2) Automatic start is possible by selecting a parameter (#6023 D0 = 1) when rewinding is completed.
- (3) This input is effective only in the MEM mode.
- (4) Disregard the RWD, EOP input when this input is used.

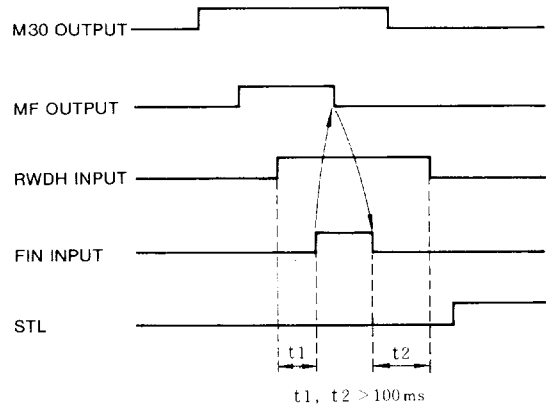

Fig. 18.25

APPENDIX A DIMENSIONS in mm

When purchasing units, be sure to approve and return the outline drawing to us.

(1) FREE-STANDING TYPE YASNAC LX3 CABINET

Dimensions in mm: 650(W) × 1500(H) × 700(D)

(2) CPU MODULE (TYPE JZNC-RK20)

DWG No.: DE8200670

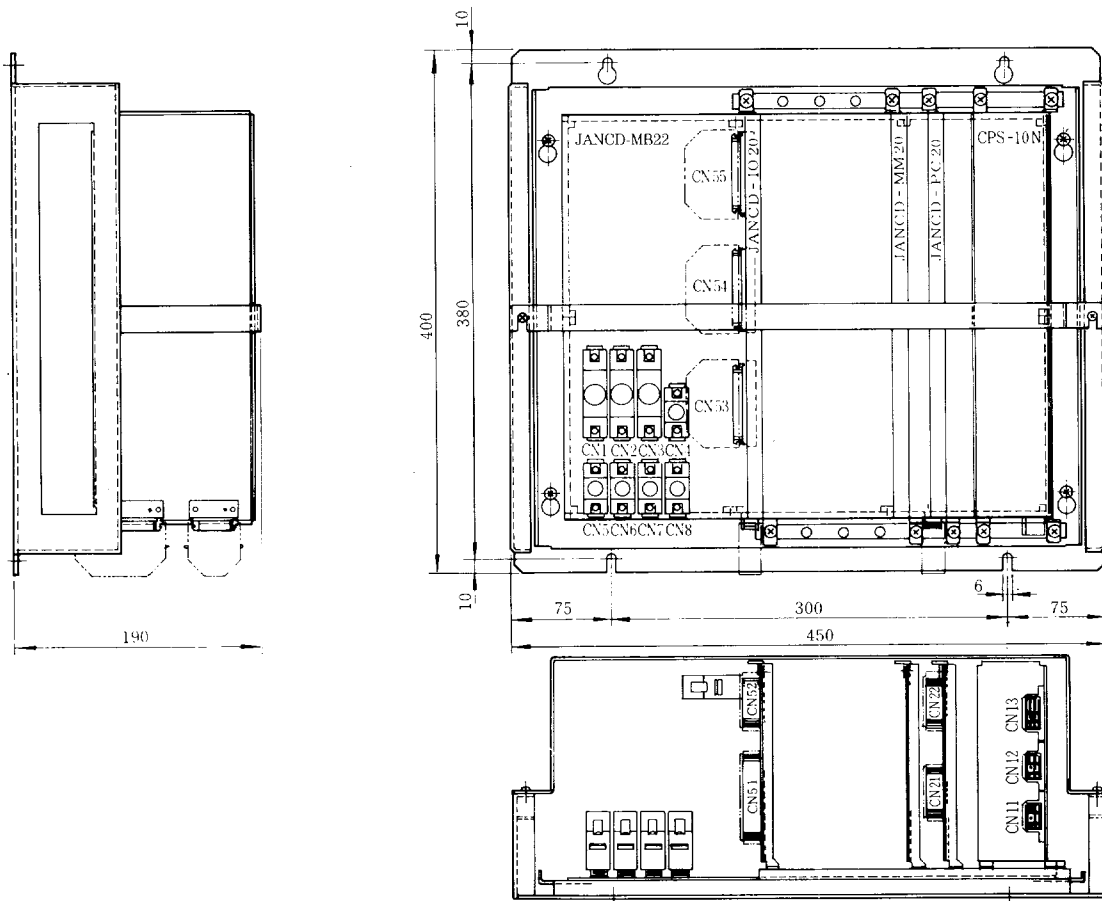

Approx Weight: 10 kg

APPENDIX A DIMENSIONS in mm (Cont'd)

(3) NC OPERATOR'S STATION WITH KEYBOARD
ON RIGHT SIDE OF CRT (TYPE JZNC-OP101)

DWG No. : DE8200672

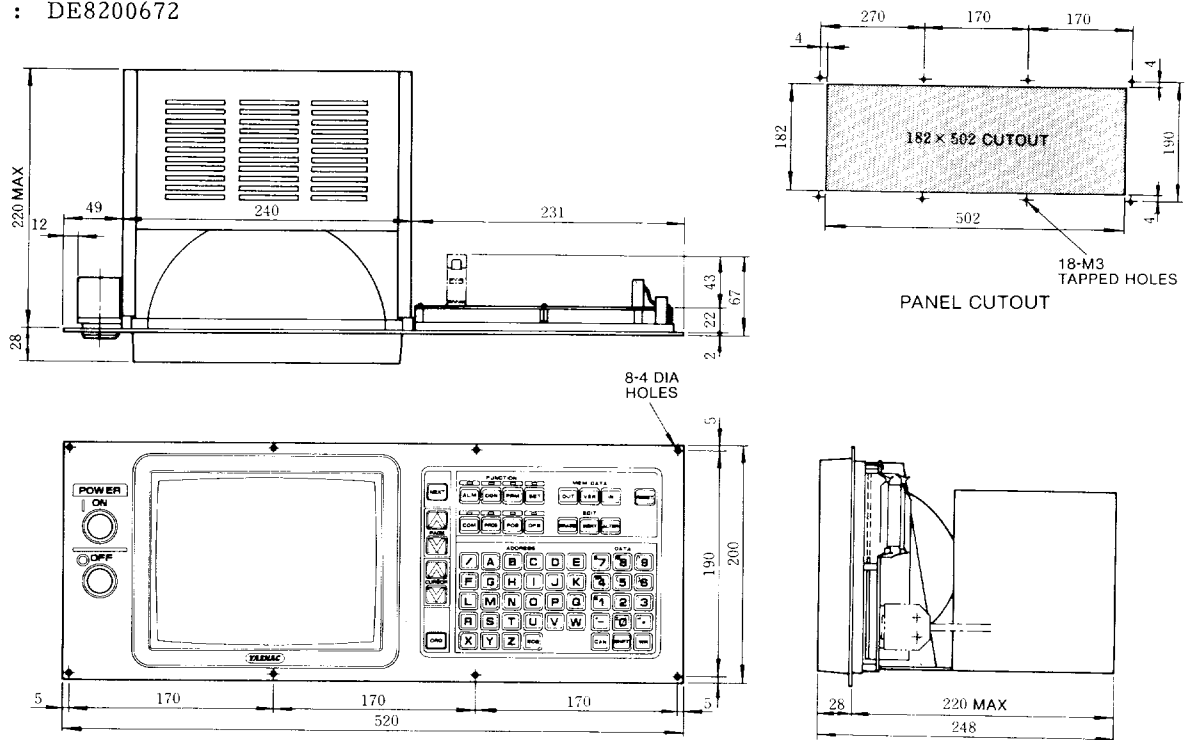

- Note:
1. Panel finish—N1.5 Munsell notation, Dull finish
 2. Approx weight—5.5 kg

(4) NC OPERATOR'S STATION WITH KEYBOARD
BELOW CRT (TYPE JZNC-OP95)

DWG No. : DE8304572

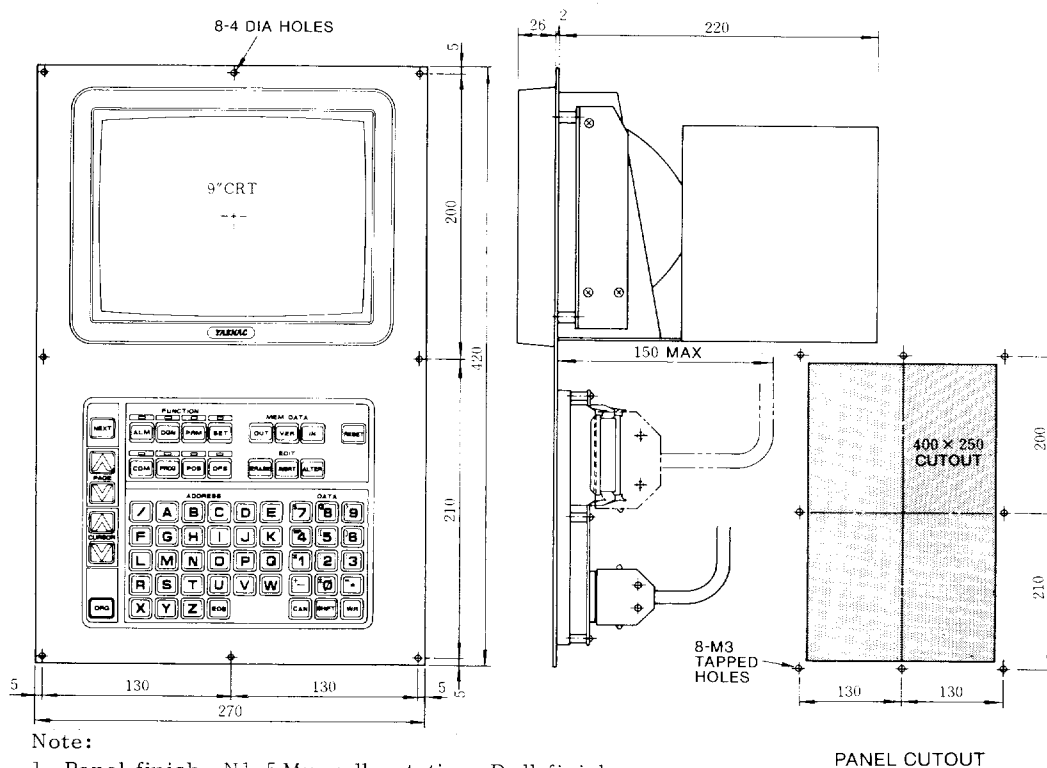

- Note:
1. Panel finish—N1.5 Munsell notation, Dull finish
 2. Approx weight—5.5 kg

(5) TAPE READER UNIT (MODEL 2800)

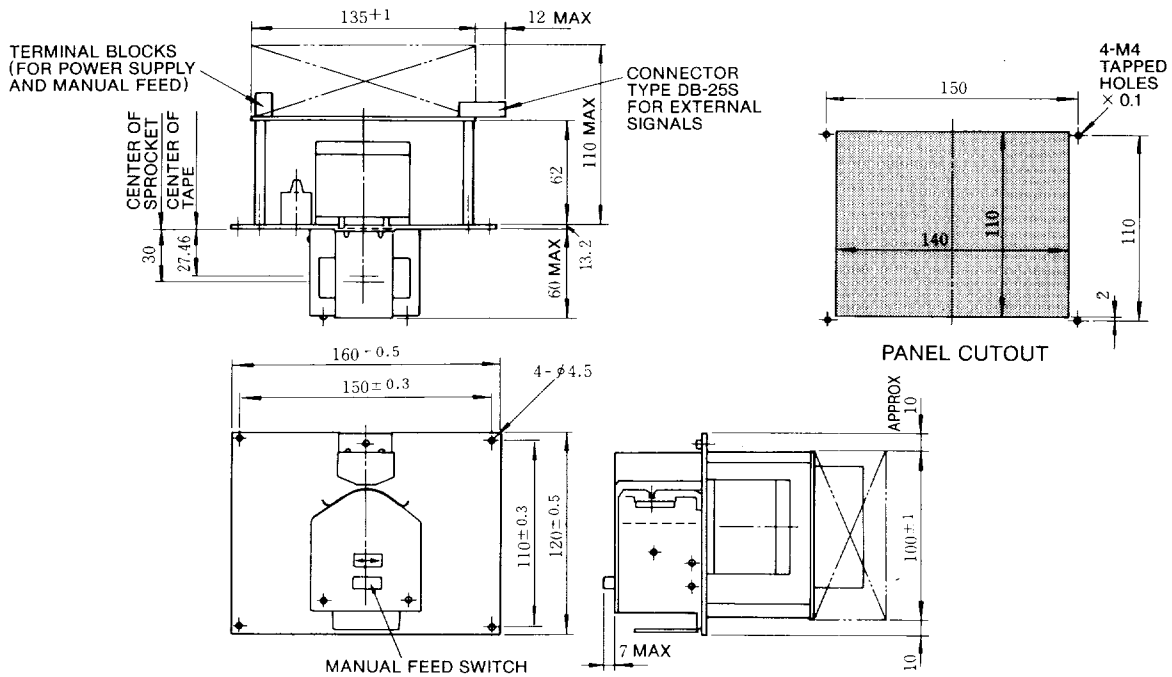

(6) SERVO UNITS

(a) Types CACR-SR03SB to -SR20SB

DWG No. : DE8407409

(b) Type CACR-SR30SB

DWG No. : DE8407410

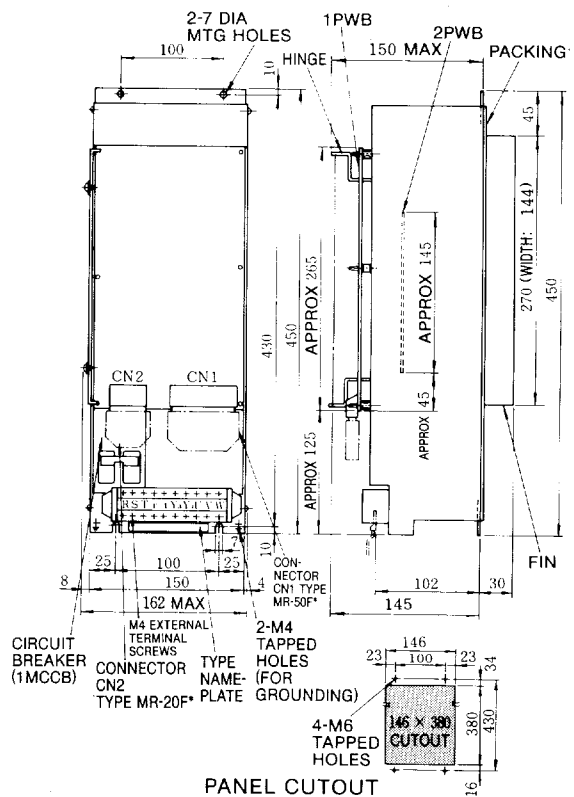
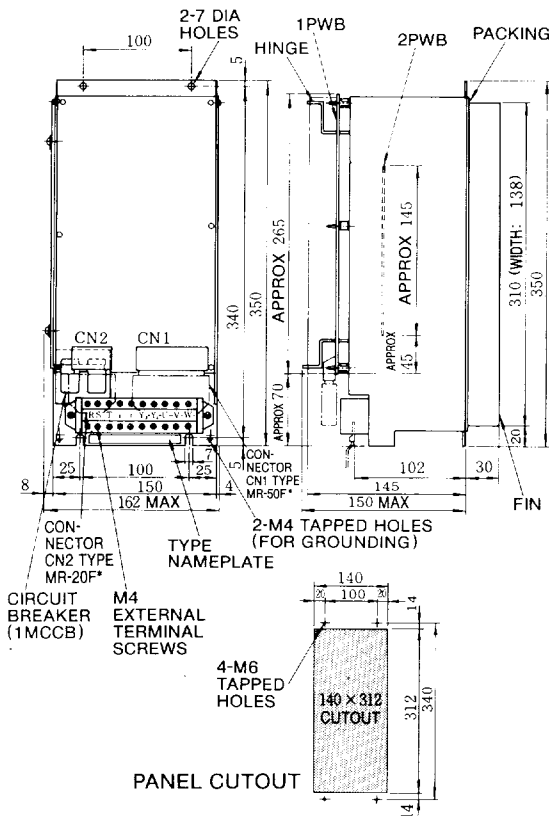

Approx weight: 5.5 kg

* Made by Honda Tsushin Co., Ltd.

Approx weight: 9 kg

* Made by Honda Tsushin Co., Ltd.

APPENDIX A DIMENSIONS in mm (Cont'd)

(7) REGENERATIVE RESISTOR

(a) Type MO-4H-AS, 30W, 100-OHM
DWG No. : D8407914

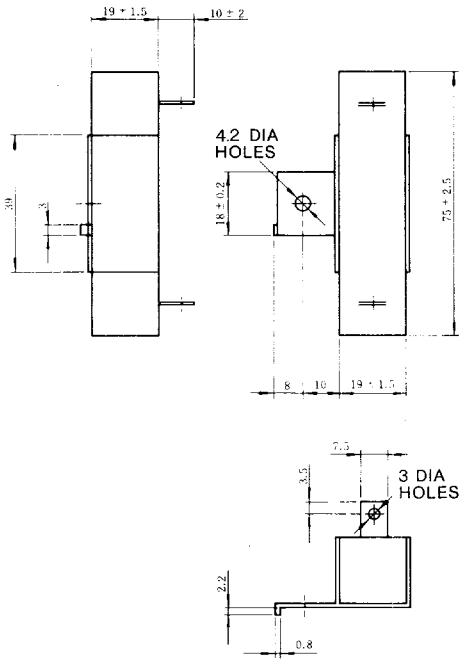

(b) Type MO-70W-50K
DWG No. : DE8404870

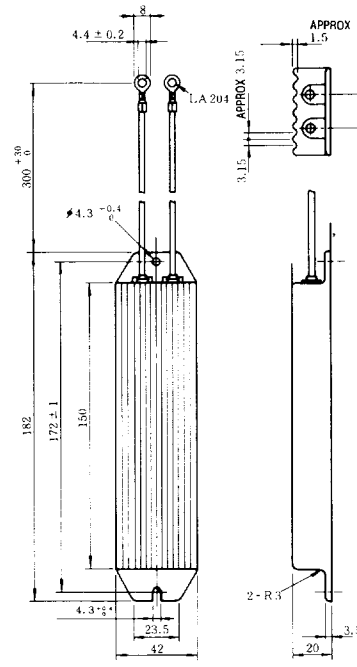

(c) Type MO-140W-25K
DWG No. : D8407913

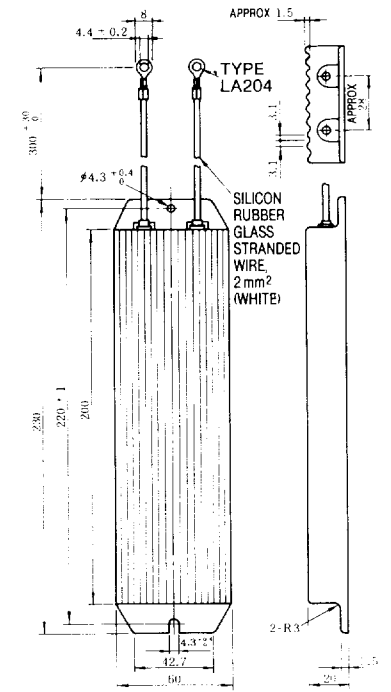

(8) LINE FILTER

(a) Types LF310, LF320, LF330
DWG No. : DE8302999

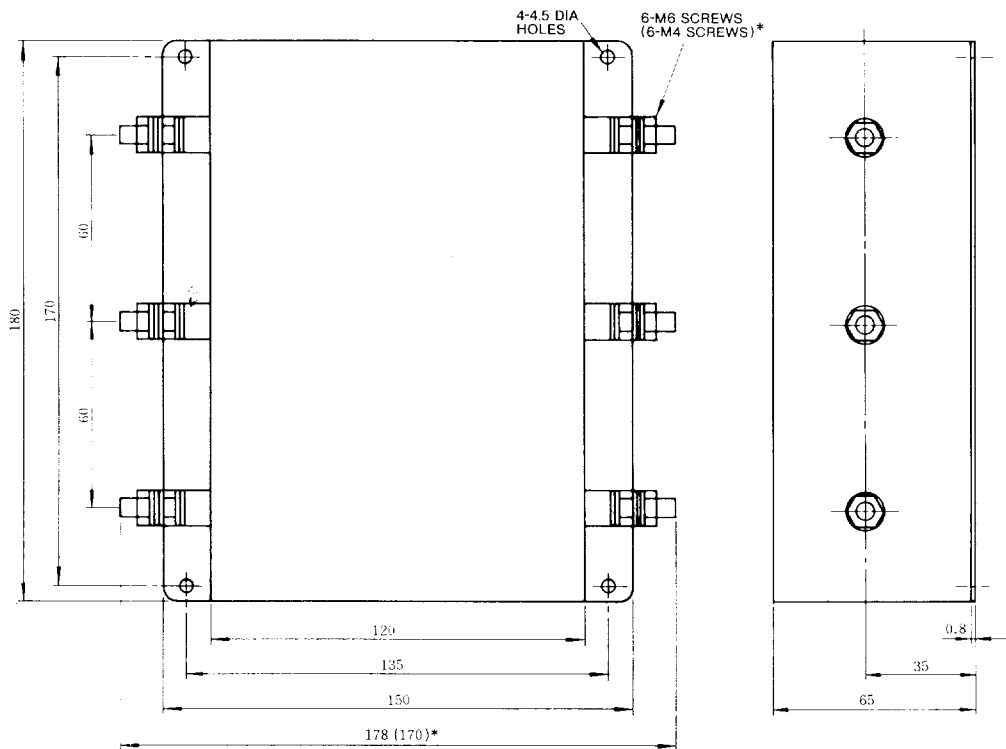

Approx weight: 2.4 kg(1.9kg)*

* For type LF310

(b) Type LF340

DWG No. : DE 8303000

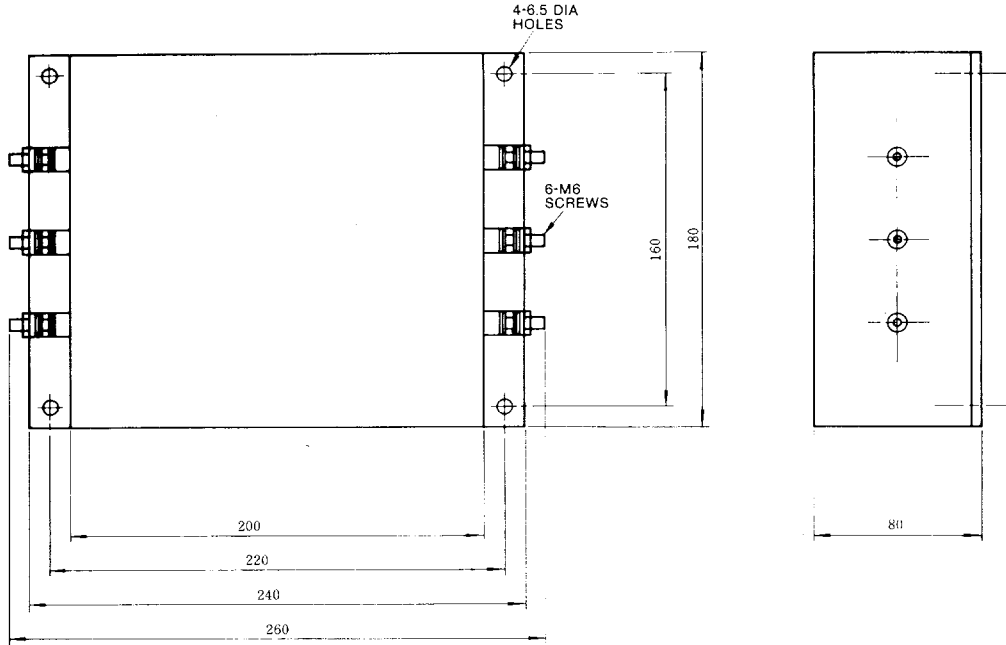

Approx Weight: 5 kg

(9) POWER SUPPLY UNIT FOR BRAKE (TYPES OPR109F, OPR109A)

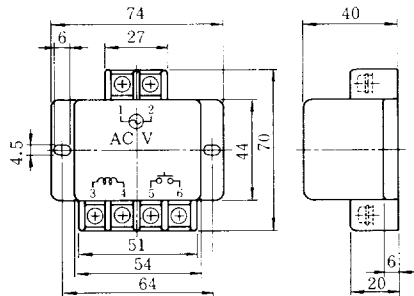

• Circuit Diagram of Type OPR109F

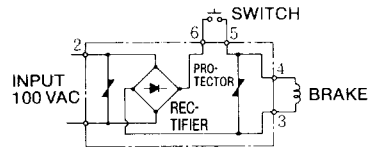

• Circuit Diagram of Type OPR109A

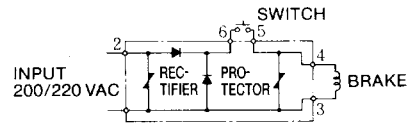

Note:

- Do not short-circuit output terminals Nos. 3 and 4.
- Tightly fasten the screws of the terminal blocks.
- Contains a protective device. Additional external protective devices are not necessary.
- The making and braking current of the contact for terminal Nos. 5 and 6 must be 5 to 10 times the rated current of the clutch brake to be used. The contacts should be for DC make and break.

• Specifications

Type	Rectifier System	Frequency Hz	AC Input Voltage V	DC Output Voltage V	DC Output Current A	Approx Weight kg
OPR-109A	Single-phase half wave	50/60	200	90	1	0.1
OPR-109F	Single-phase full wave	50/60	100	90	1	0.1

APPENDIX A DIMENSIONS in mm (Cont'd)

(10) MANUAL PULSE GENERATOR

(a) Type MGX-10B

DWG No. : DE8302990

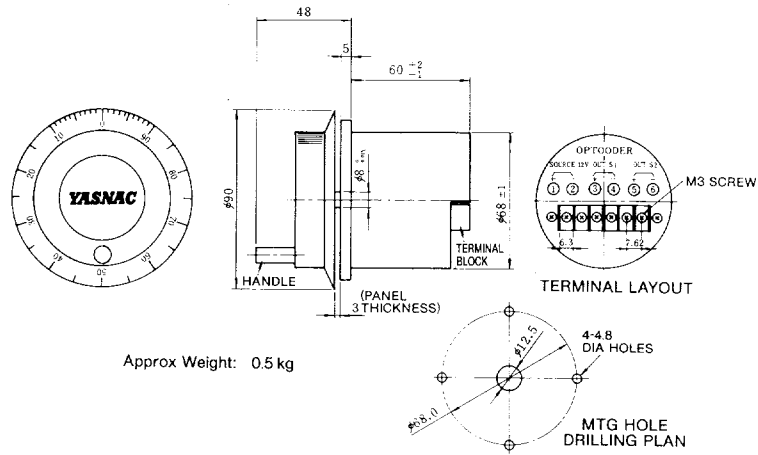

(b) Type MGZ-10B

DWG No. : DE6322075

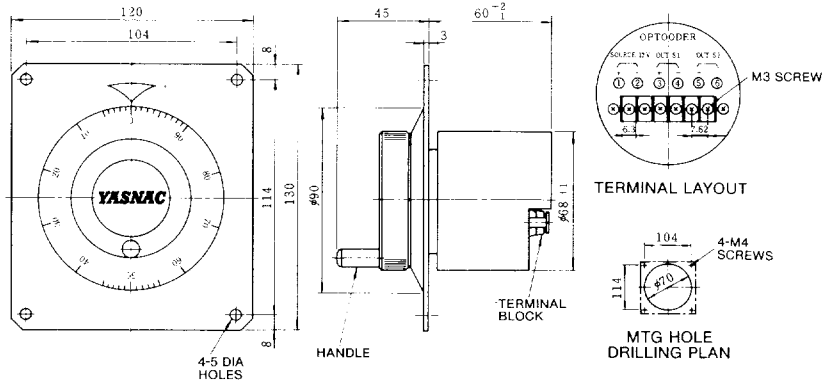

(c) Type MGY-10B

DWG No. : DE6322074

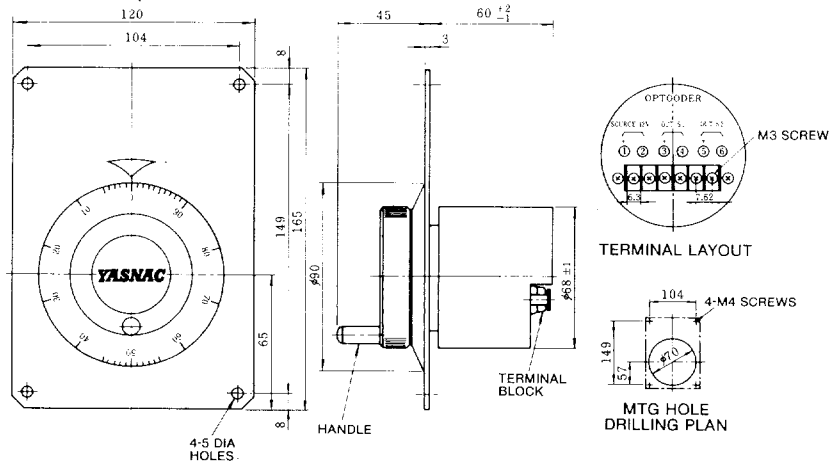

(11) PORTABLE TAPE READER (TYPE JZNC-AU08)
 DWG No. : D8407912 .

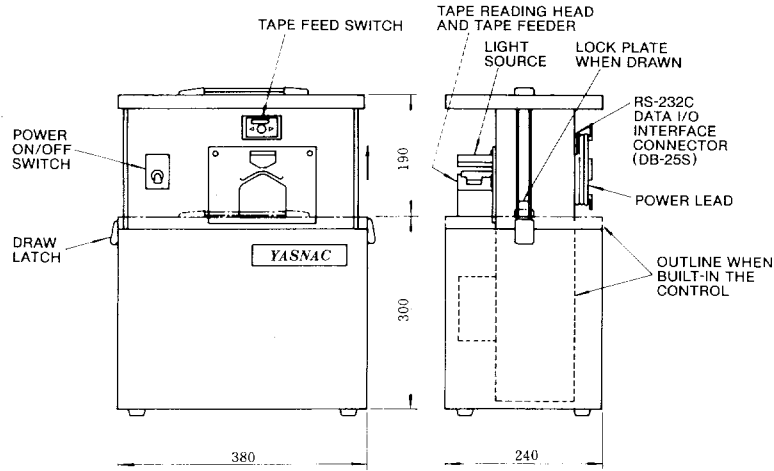

Portable Tape Reader Drawn

(12) SPINDLE PULSE GENERATOR

(a) Types PC-1024ZL-4K-1, PC-1024ZL-6K-1

Drawing No. : DE6429539

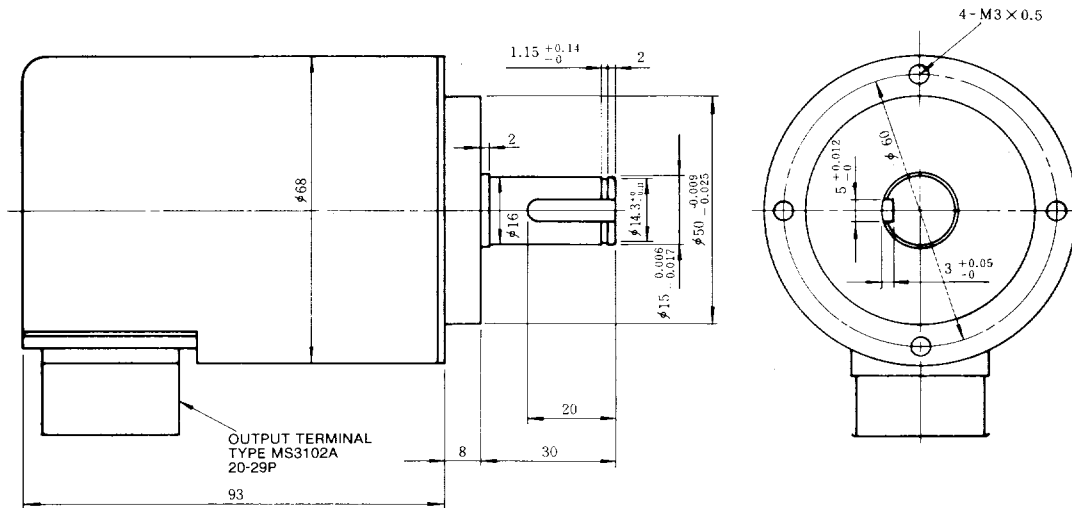

• Specifications

Power Supply	+ 5 VDC $\pm 5\%$, 350mA max	
Number of Pulses	A- and B-phases: 1024 p/rev C-phase: 1 p/rev	
Max Response Speed	4 k: 4000 rpm 6 k: 6000 rpm	
Operation Temperature	0 to + 60 °C	
Output Terminals	Type MS3102A, 20-29P	
Input Shaft Inertia	1×10^{-3} kg·cm·s ² max	
Input Starting Torque	1 kg·cm max	
Allowable Input Shaft Load	Thrust Load	At stop: 10kg max, At rotating: 2kg max
	Radial Load	At stop: 20kg max, At rotating: 3kg max
Approx Weight	1.5 kg	

• Output Terminal Layout

A	PA	G	N	* PA
B	PC	H	+ 5 V	* PC
C	PB	J	R	* PB
D		K	0 V	S
E	FG	L	T	
F		M		

APPENDIX A DIMENSIONS in mm (Cont'd)

(b) Types PC-1024ZL-4K-68, PC-1024ZL-6K-68

Drawing No. : DE6429540

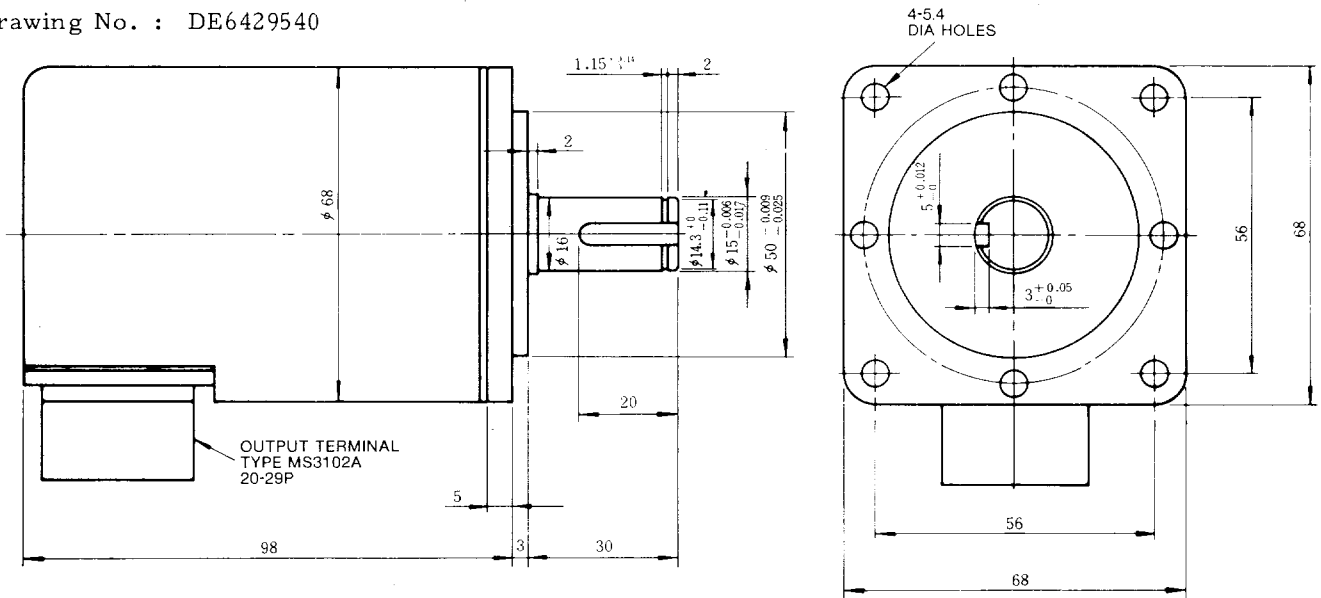

• Specifications

Power Supply	+5 VDC ± 5%, 350mA max
Number of Pulses	A- and B-phases: 1024 p/rev C-phase: 1 p/rev
Max Response Speed	4 k: 4000 rpm 6 k: 6000 rpm
Operation Temperature	0 to +60 °C
Output Terminals	Type MS3102A, 20-29P

Input Shaft Inertia	1×10^{-3} kg·cm·s ² max	
Input Starting Torque	1 kg·cm max	
Allowable Input Shaft Load	Thrust Load	At stop: 10kg max, At rotating: 2kg max
	Radial Load	At stop: 20kg max, At rotating: 3kg max
Approx Weight	1.5 kg	

• Output Terminal Layout

A	PA	G	N	*PA
B	PC	H	+5V	*PC
C	PB	J		*PB
D		K	0V	S
E	FG	L		T
F		M		

(c) Types PC-1024ZL-4K-160, PC-1024ZL-6K-160

Drawing No. : DE6429541

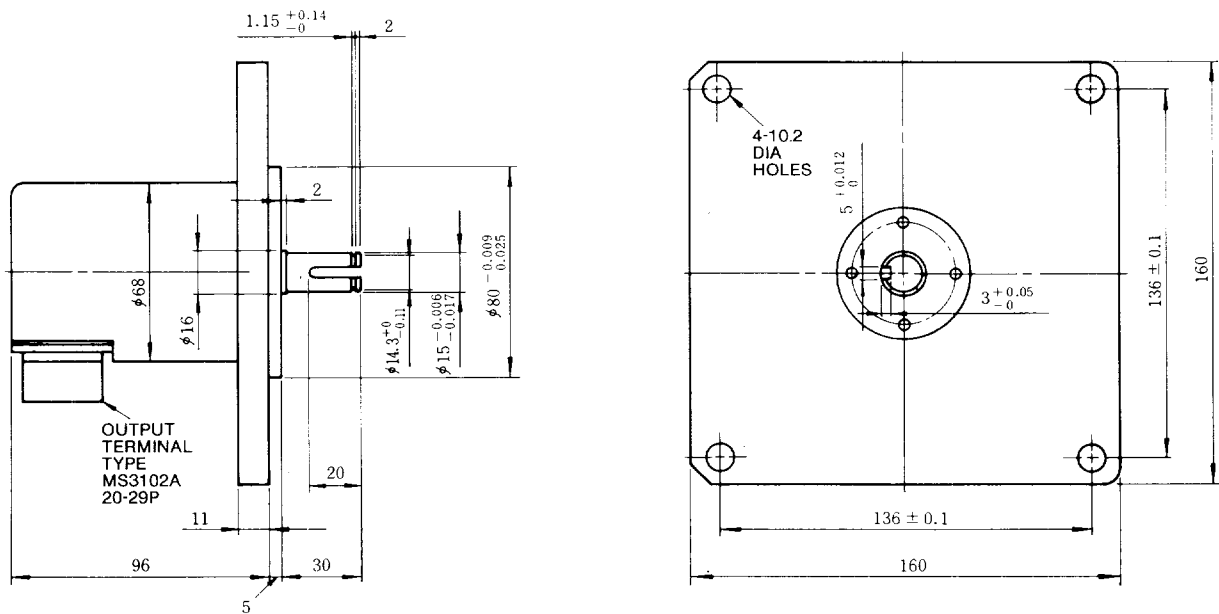

• Specifications

Power Supply	+5 VDC ± 5%, 350mA max
Number of Pulses	A- and B-phases: 1024 p/rev C-phase: 1 p/rev
Max Response Speed	4 k: 4000 rpm 6 k: 6000 rpm
Operation Temperature	0 to +60 °C
Output Terminals	Type MS3102A, 20-29P

Input Shaft Inertia	1×10^{-3} kg·cm·s ² max	
Input Starting Torque	1 kg·cm max	
Allowable Input Shaft Load	Thrust Load	At stop: 10kg max, At rotating: 2kg max
	Radial Load	At stop: 20kg max, At rotating: 3kg max
Approx Weight	1.5 kg	

• Output Terminal Layout

A	PA	G	N	*PA
B	PC	H	+5V	*PC
C	PB	J		*PB
D		K	0V	S
E	FG	L		T
F		M		

APPENDIX B I/O PORT ADDRESS SETTING

(1) IO 20

Short plug (SW1) setting and I/O module Nos. are shown below.

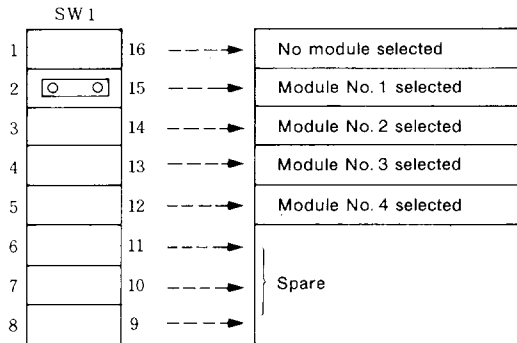

(2) SP 20

Short plug (SW2) setting and I/O area Nos. are shown below.

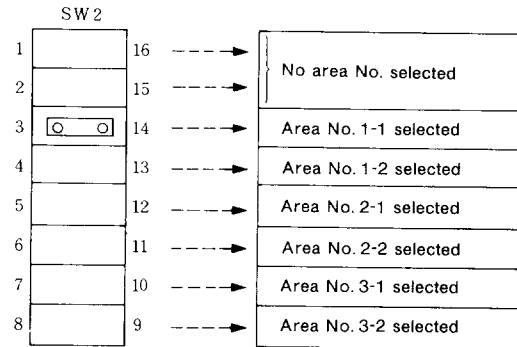

(3) ADDRESS CLASSIFICATION (COMPARISON BETWEEN LX2 AND LX3)

Address classifications of IO01B, IO02, SP20, IO20-01, IO20-02, and IO20-03 are as follows:

(a) Input Port

IO 01 B		IO 02		SP 20-02		IO 20-01		IO 20-02		IO 20-03	
Module No.	Address Port	Area No.	Address Port	Area No.	Address Port	Module No.	Address Port	Module No.	Address Port	Module No.	Address Port
1	# 1000 to # 1013	1-1	# 1000 to # 1007	1-1	# 1000 to # 1007	1	# 1005 to # 1009 # 1013	1	# 1000 to # 1009 # 1013	1	# 1000 to # 1013
		1-2	# 1008 to # 1015	1-2	# 1008 to # 1015						
2	# 1016 to # 1029	2-1	# 1016 to # 1023	2-1	# 1016 to # 1023	2	# 1021 to # 1025 # 1029	2	# 1016 to # 1025 # 1019	2	# 1016 to # 1029
		2-2	# 1024 to # 1031	2-2	# 1024 to # 1031						
3	# 1032 to # 1045	3-1	# 1032 to # 1039	3-1	# 1032 to # 1039	3	# 1037 to # 1041 # 1045	3	# 1032 to # 1041 # 1045	3	# 1032 to # 1045
		3-2	# 1040 to # 1047	3-2	# 1040 to # 1047						
4	# 1048 to # 1061					4	# 1053 to # 1057 # 1061	4	# 1048 to # 1057 # 1061	4	# 1048 to # 1061
LX2						LX3					

APPENDIX B I/O PORT ADDRESS SETTING (Cont'd)

(b) Output Port

IO 01 B		IO 02		SP20-02		IO 20-01		IO 20-02		IO 20-03	
Module No.	Address Port	Area No.	Address Port	Area No.	Address Port	Module No.	Address Port	Module No.	Address Port	Address Port	Address Port
1	# 1100 to # 1107	1-1	# 1100 to # 1107	1-1	# 1100 to # 1107	1	# 1100 to # 1105	1	# 1100 to # 1105	1	# 1100 to # 1107
		1-2	# 1108 to # 1115	1-2	# 1108 to # 1115						
2	# 1116 to # 1123	2-1	# 1116 to # 1123	2-1	# 1116 to # 1123	2	# 1116 to # 1121	2	# 1116 to # 1121	2	# 1116 to # 1123
		2-2	# 1124 to # 1131	2-2	# 1124 to # 1131						
3	# 1132 to # 1139	3-1	# 1132 to # 1139	3-1	# 1132 to # 1139	3	# 1132 to # 1137	3	# 1132 to # 1137	3	# 1132 to # 1139
		3-2	# 1140 to # 1147	3-2	# 1140 to # 1147						
4	# 1148 to # 1155					4	# 1148 to # 1153	4	# 1148 to # 1153	4	# 1148 to # 1155

LX2
LX3

APPENDIX C STANDARD WIRING COLORS OF YASNAC

The standard wiring colors of YASNAC are as follows:

Items		Wiring
Circuit		Green
Main Circuit	200 VAC	Black
	100 VAC	Yellow
Control Circuit (100 VAC)		Yellow
DC Power Circuit	+ 5 V, 12 V, 24 V	Red
	12 V	Red
	0 V	Black
DC Signal Line	0.2 SG	Gray
	Other than 0.2 SG	Brown
Ground Wire		Green/Yellow

NOTES

YASNAC LX3

CNC SYSTEM FOR TURNING APPLICATIONS

CONNECTING MANUAL

TOKYO OFFICE Ohtemachi Bldg, 1-6-1 Ohtemachi, Chiyoda-ku, Tokyo, 100 Japan
Phone (03) 3284-9111 Telex YASKAWA J33530 Fax (03) 3284-9034

SEOUL OFFICE 8th Floor Seoul Center Bldg, 91-1, Sogong-Dong, Chung-ku, Seoul, Korea 100-070
Phone (02) 776-7844 Fax (02) 753-2639

TAIPEI OFFICE Shen Hsiang Tang Sung Chiang Building 10F 146 Sung Chiang Road, Taipei Taiwan
Phone (02) 563-0010, -7732 Fax (02) 567-4677

YASKAWA ELECTRIC AMERICA, INC.
Chicago-Technical Center
3160 MacArthur Blvd. Northbrook, IL 60062-1917, U.S.A.
Phone (708) 291-0411 Fax (708) 291-1018

Los Angeles Office
5626 Corporate Avenue Cypress, CA 90630, U.S.A.
Phone (714) 828-9692 Fax (714) 828-1165

New Jersey Office Riverdale One, 44 Route 23 North, Suite 5 Riverdale NJ 07457-1619, U.S.A.
Phone (201) 835-9512 Fax (201) 835-9511

YASKAWA ELECTRIC EUROPE GmbH
Monschauer Strasse 1, 40549 Düsseldorf 11, Germany
Phone (0211) 950030 Telex (41) 8588673 YASD D Fax (0211) 507737

YASKAWA ELECTRIC (SINGAPORE) PTE. LTD.
Head Office CPF Bldg, 79 Robinson Road # 13-05, Singapore 0106, SINGAPORE
Phone 2217-530 Telex (87) 24890 YASKAWA RS Fax 224-5854

Service Center 221 Henderson Road, # 07-20 Henderson Building Singapore 0315, SINGAPORE
Phone 276-7407 Fax 276-7406

YATEC ENGINEERING CORPORATION
Shen Hsiang Tang Sung Chiang Building 10F 146 Sung Chiang Road, Taipei, Taiwan
Phone (02) 563-0010 Fax (02)567-4677



YASKAWA

YASKAWA ELECTRIC CORPORATION

TOE-C843-9.22B

© Printed in Japan October 1993 86-8 0.6WA ◇